

SEOKWANG
LIGHTING COLLECTION

LED 가로등



LED 보안등



LED 경관조명등



LED 투광등/ LED터널등

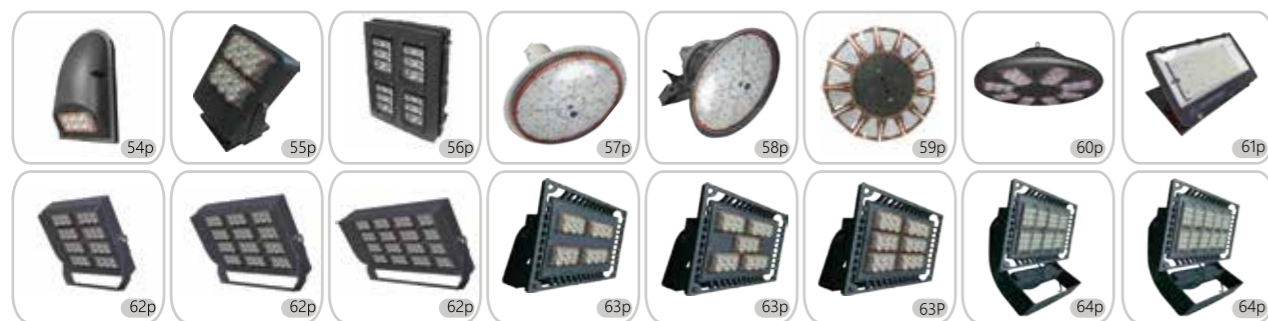

LED터널등



STS 가로등주

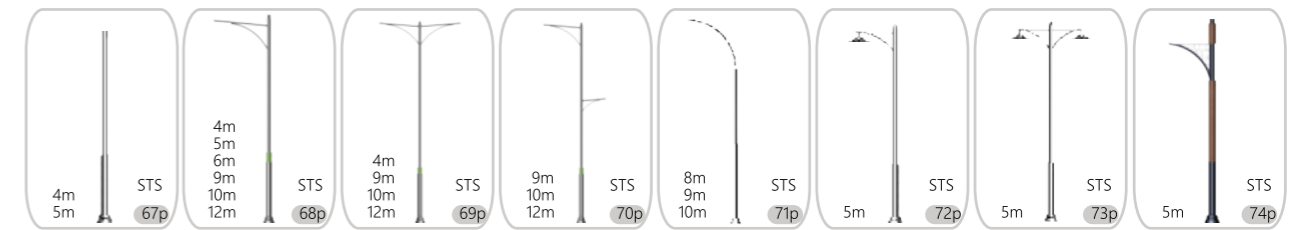

STEEL 가로등주

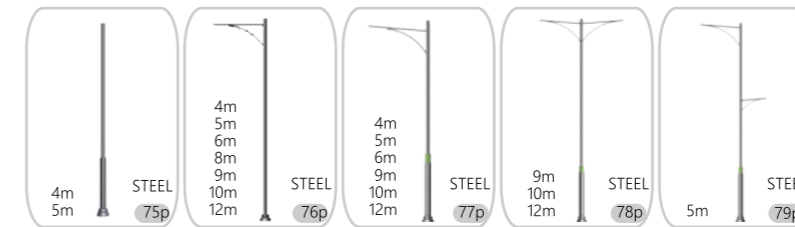

태양광



가로등주 부속자재



LED 실내조명등

LED Downlight



LED Edge Flat Series

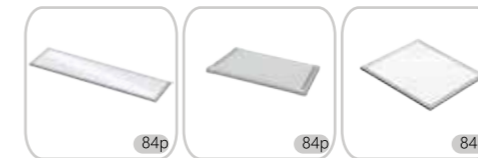

LED Flat Series



LED 회전철판등 / LED 갓등(RaceWay주차장등) / LED 방습등 / LED 직부등 / LED CMB등 / LED 원형직부등



LED 벽부등 / LED 센서등

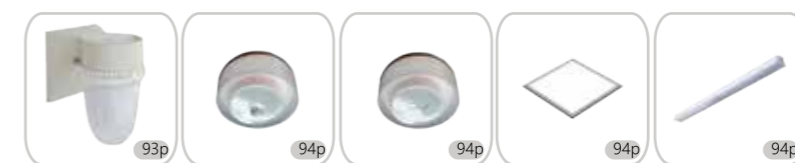

LED 포커스 모듈형 빔공해 방지용 가로등 SKL-16GR-1012KG

G2B물품식별번호 23080206

모듈 LED 25w

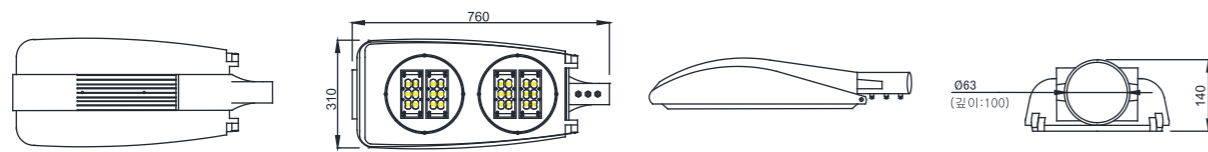

Description

광원 기판 360°회전 + 모듈 좌우회전 : 빛 방향 + 조사각 자유제어
 최적조명 : 2차선 도로, 4차선 도로
 - 유실되는 빛 차단, 효율적인 빛 활용
 - 빛 공해 차단기능 : 건물, 농경지 등에 침투하는 빛 차단,
 기존 빔가림장치는 가림판 등을 설치, 온전한 빛 활용 저하 및 외관 해치는 문제 발생

작하조도 / 배광곡선

Test. 100m x 100m x 10m SKL-16GR-1012KG

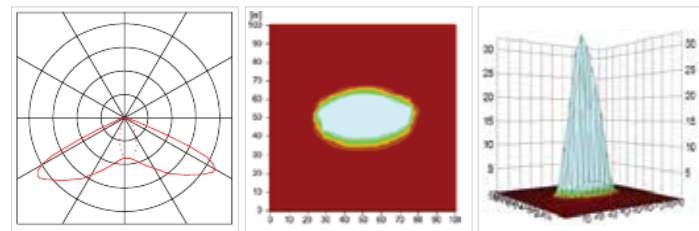

일반조명 : 빛 공해 (농작물 피해) 빛 공해 차단조명

Specification

모델명 Model name	물품식별번호 G2B	전력 Power consumption	광효율 Luminous efficiency	연색성 CRI	색온도 Color temperature	인증 Certification	금액 Unit price
SKL-16GR-8000KS	23061976	80W	95이상	75이상	5000K	☞	530,000
SKL-16GR-1011KS	23008959	100W	95이상	75이상	5000K	☞	550,000
SKL-16GR-1012KG	23080206	100W	122	79	5000K	☞☞☞☞☞☞	644,000
SKL-17GR-1013KG	23450137	100W	136	83	4000K	☞☞☞☞	

◆ 광원 기판 360°회전



◆ 모듈 좌우 회전 기능(약120°)

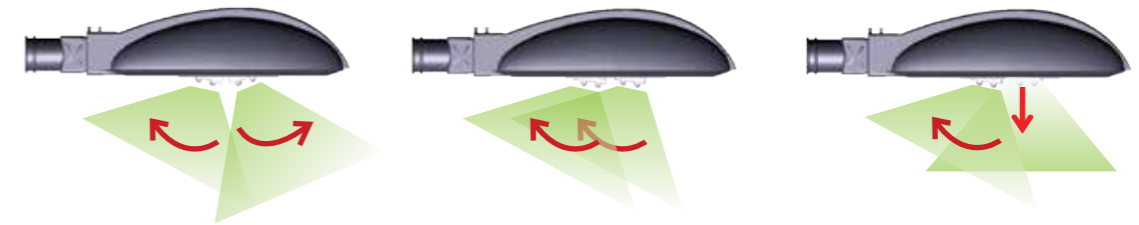

◆ 주요 필요부분 선택 집중 조명(CUT-OFF)



LED 코브라 가로등 SKL-16GR-1512KG

G2B물품식별번호 23077945

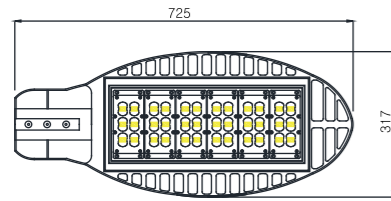

Description

모듈 분리형으로 호환성 및 유지보수 편리. 에너지 절감 효과에 초점을 맞춘 고효율 가로등 제품임. 광학렌즈를 적용하여 도로조명에 적합한 배광을 실현(광효율 130lm/w)함.

적하조도 / 배광곡선

Test. 100m x 100m x 10m SKL-16GR-1512KG

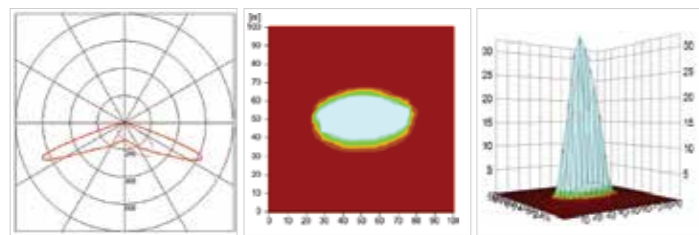

Specification

모델명 Model name	물품식별번호 G2B	전력 Power consumption	광효율 Luminous efficiency	연색성 CRI	색온도 Color temperature	인증 Certification	금액 Unit price
SKL-16GR-8001KS	23063958	80W	95이상	75이상	5000K	☞	500,000
SKL-16GR-1012KS	23063959	100W	95이상	75이상	5000K	☞	500,000
SKL-16GR-1210KS	23063960	120W	95이상	75이상	5000K	☞	530,000
SKL-16GR-1212KG	23077944	120W	133	79	5000K	☞☞☞☞☞☞☞	639,000
SKL-16GR-1510KS	23063961	150W	95이상	75이상	5000K	☞	550,000
SKL-16GR-1512KG	23077945	150W	132	77	5000K	☞☞☞☞☞☞☞	695,000

LED 가로등 SKL-16GR-1015KS

G2B식별번호 23074484



SKL-16GR-1015KS
LED 100W

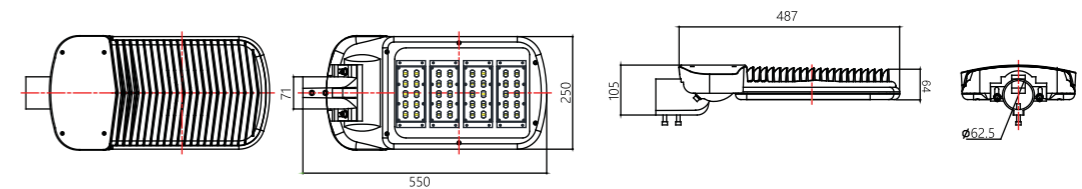

Description

모듈 분리형으로 호환성 및 유지보수 편리. 에너지 절감 효과에 초점을 맞춘 고효율 가로등 제품임. 광학렌즈를 적용하여 도로조명에 적합한 배광을 실현(광효율 130lm/w)함. 폴높이 8~10미터(도로조명용)

적하조도 / 배광곡선

Test. 50m x 50m x 5m SKL-16GR-1015KS

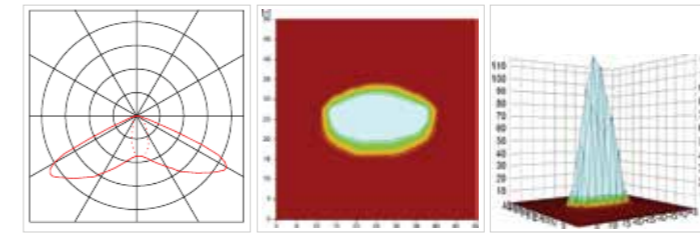

Specification

모델명 Model name	물품식별번호 G2B	전력 Power consumption	광효율 Luminous efficiency	연색성 CRI	색온도 Color temperature	인증 Certification	금액 Unit price
SKL-16GR-7500KS	23074483	75W	95이상	75이상	5000K	☞	480,000
SKL-16GR-1015KS	23074484	100W	95이상	75이상	5000K	☞	500,000

LED 가로등

SKL-16GR-1511KS

G2B물품식별번호 23077005



LED 가로등

SKL-16GR-2010KS

G2B물품식별번호 23074481



SKL-16GR-1511KS
LED 150W



SKL-16GR-2010KS
LED 200W

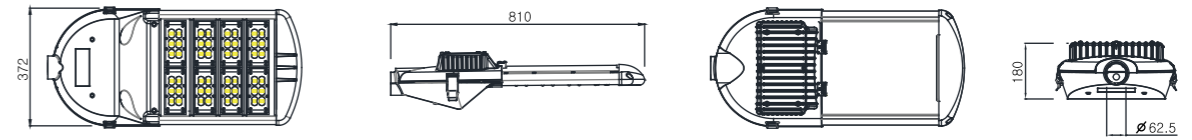
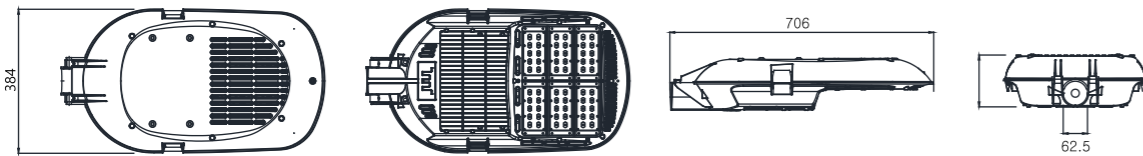

Description

모듈 분리형으로 호환성 및 유지보수 편리. 에너지 절감 효과에 초점을 맞춘 고효율 가로등 제품임. 광학렌즈를 적용하여 도로조명에 적합한 배광을 실현(광효율 130lm/w)함.

Description

모듈 분리형으로 호환성 및 유지보수 편리. 에너지 절감 효과에 초점을 맞춘 고효율 가로등 제품임. 광학렌즈를 적용하여 도로조명에 적합한 배광을 실현(광효율 130lm/w)함.

직하조도 / 배광곡선

Test. 100m x 100m x 10m SKL-16GR-1511KS

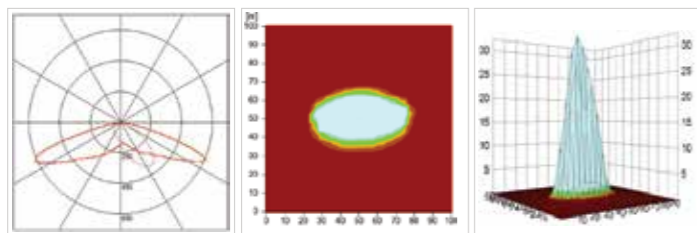

직하조도 / 배광곡선

Test. 100m x 100m x 10m SKL-17GR-2500KG

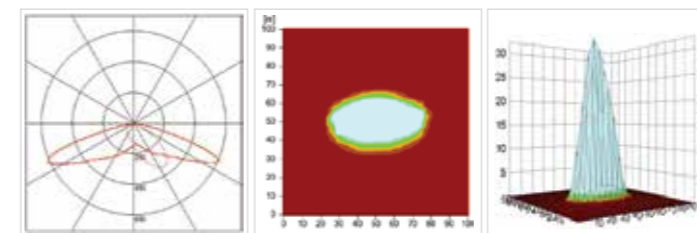

Specification

모델명 Model name	물품식별번호 G2B	전력 Power consumption	광효율 Luminous efficiency	연색성 CRI	색온도 Color temperature	인증 Certification	금액 Unit price
SKL-16GR-1013KS	23077004	100W	95이상	75이상	5000K	☞	539,000
SKL-16GR-1511KS	23077005	150W	95이상	75이상	5000K	☞	568,000

Specification

모델명 Model name	물품식별번호 G2B	전력 Power consumption	광효율 Luminous efficiency	연색성 CRI	색온도 Color temperature	인증 Certification	금액 Unit price
SKL-16GR-1014KS	23074479	100W	95이상	75이상	5000K	☞	539,000
SKL-17GR-1000KG	23212419	100W	132	78	5000K	☞☞☞☞☞	593,000
SKL-16GR-1512KS	23074480	150W	95이상	75이상	5000K	☞	568,000
SKL-17GR-1500KG	23212420	150W	142	77	5000K	☞☞☞☞☞	720,000
SKL-16GR-2010KS	23074481	200W	95이상	75이상	5000K	☞	774,000
SKL-16GR-2510KS	23074482	250W	95이상	75이상	5000K	☞	862,000
SKL-17GR-2500KG		250W	143	78	5000K	☞☞☞☞☞	

LED 가로등 SKL-14GR-1511KG

G2B식별번호 22889265

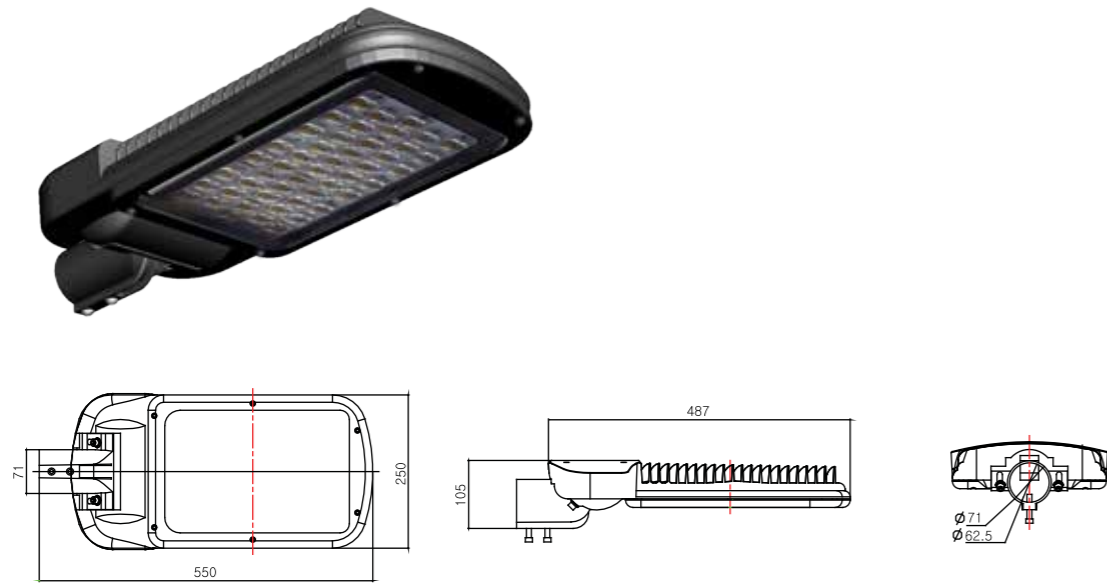

Description

LED 광원을 이용한 가로등기구로서 미려한 디자인과 과학적인 방열 설계로 광원의 수명을 극대화 시켰으며 이상적인 광원 배치로 자연스런 색상연출을 할 수 있도록 제작되었다.

작하조도 / 배광곡선

Test. 50m x 50m x 10m SKL-14GR-1511KG

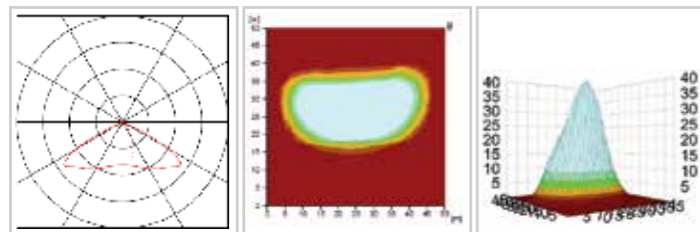

Specification

모델명 Model name	물품식별번호 G2B	전력 Power consumption	광효율 Luminous efficiency	연색성 CRI	색온도 Color temperature	인증 Certification	금액 Unit price
SKL-14GR-9001KG		90W	95이상	75이상	5700K	☞☞	₩
SKL-14GR-1011KG		100W	95이상	75이상	5700K	☞☞	₩
SKL-14GR-1211KG		120W	95이상	75이상	5700K	☞☞	₩
SKL-14GR-1511KG		150W	95이상	75이상	5700K	☞☞	₩

LED 청사초롱 가로등 SKL-16GR-1010KS

G2B물품식별번호 23008958

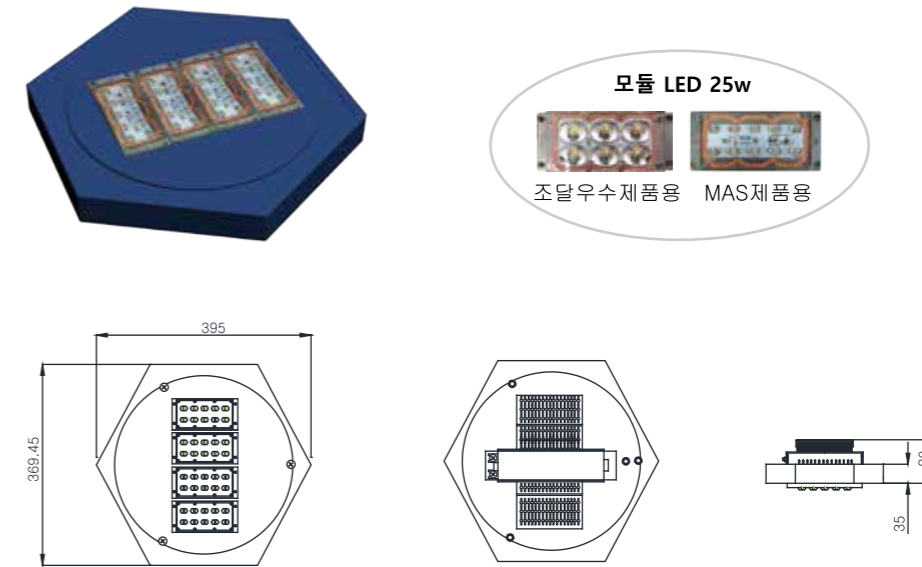

Description

청사초롱 등기구는 민족고유의 전통미를 갖춘 등기구이다. 그러나 등기구 프레임 안에 갇힌 MH 또는 LED램프빛의 확산의 한계성으로 인해 W수가 높은 고소비전력램프를 사용하게 되고 그에 따라 전력비도 상승하게 되나 프레임 안에 갇힌 램프구조상 도로조명으로서 표준조도수치를 충족시키기 어렵다. 이를 개선, 보완한 LED모듈을 청사초롱 등기구 저변에 부착시킴으로써 전통미를 살리고 표준조도를 넉넉히 충족시켜 1석2조의 효과를 얻게한다.

작하조도 / 배광곡선

Test. 100m x 100m x 10m SKL-16GR-1010KS

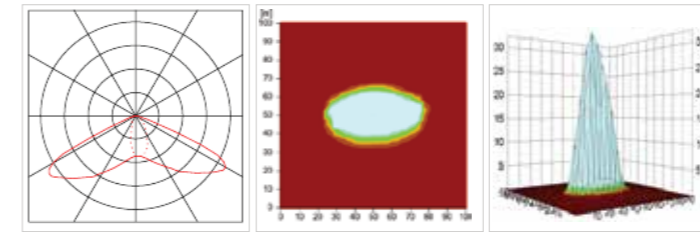

Specification

모델명 Model name	물품식별번호 G2B	전력 Power consumption	광효율 Luminous efficiency	연색성 CRI	색온도 Color temperature	인증 Certification	금액 Unit price
SKL-16GR-1010KS	23008958	100W	95이상	75이상	5000K	☞	520,000

LED 포커스 모듈형 빔공해 방지용 보안등 SKL-16BA-5003KG

G2B물품식별번호 23083987



모듈 LED 25w



광효율 152lm/w 광효율 132lm/w

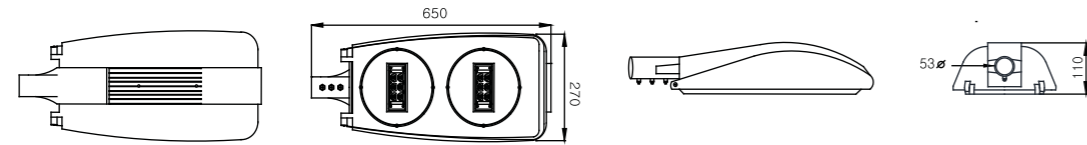

Description

광원 기판 360°회전 + 모듈 좌우회전 : 빛 방향 + 조사각 자유제어
 최적조명 : 풀높이 4~7m LED50w
 - 유실되는 빛 차단, 효율적인 빛 활용
 - 빔 공해 차단기능 : 건물, 농경지 등에 침투하는 빛 차단

직하조도 / 배광곡선

Test. 50m x 50m x 5m SKL-16BA-5003KG

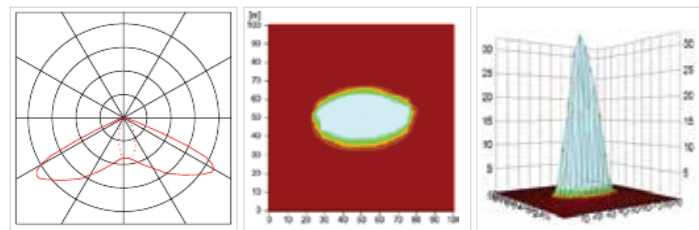

Specification

모델명 Model name	물품식별번호 G2B	전력 Power consumption	광효율 Luminous efficiency	연색성 CRI	색온도 Color temperature	인증 Certification	금액 Unit price
SKL-16BA-5003KS	23009140	50W	95이상	75이상	5000K	☞	380,000
SKL-16BA-5003KG	23083987	50W	120	80	5000K	☞☞☞☞☞☞☞☞☞☞	462,000
SKL-17BA-5004KG	23450138	50W	113	84	3000K	☞☞☞☞☞	

◆ 광원 기판 360°회전



◆ 모듈 좌우 회전 기능(약120°)

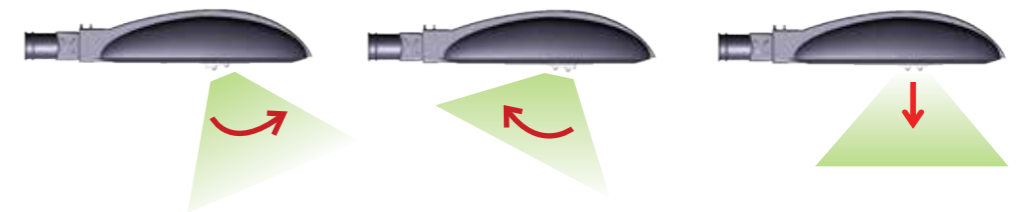

포커스모듈보안등 집중조명된 조명



빔공해로 인한 가림막이 설치된 가로등

◆ 주요 필요부분 선택 집중 조명(CUT-OFF)



조사각 자유 제어기능



농작물 빔공해 차단

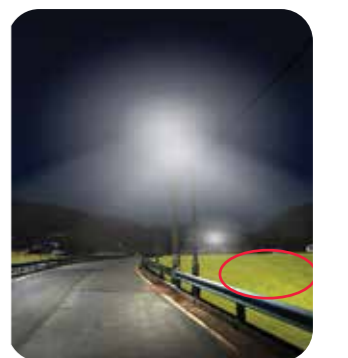

일반등기구-빔공해(농작물 피해)

LED 보안등 SKL-16BA-2502KG

G2B물품식별번호 23040718



LED 보안등 SKL-16BA-5002KG

G2B물품식별번호 23040719

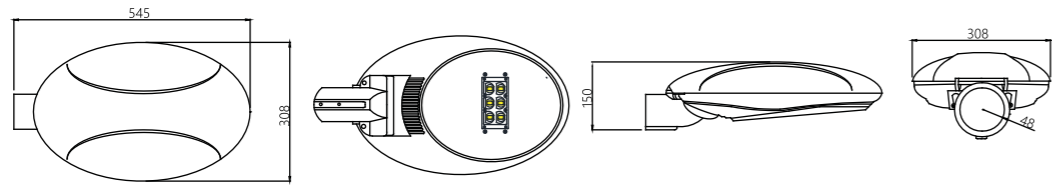

Description

모듈형 파워엘이디의 강력한 직진성의 특징을 살려 설치 위치에 따라 화려한 조명을 연출한다.
고효율제품으로 현장상황에 적절한 온전한 밝기 실현과 눈부심 없는 안전한 보안등기구임.
자연의 빛에 가까운 엘이디조명의 특성을 십분 활용한 정교한 연출이 필요한곳에 적절한 보안등기구임.

직하조도 / 배광곡선

Test. 50m x 50m x 3m SKL-16BA-2502KG

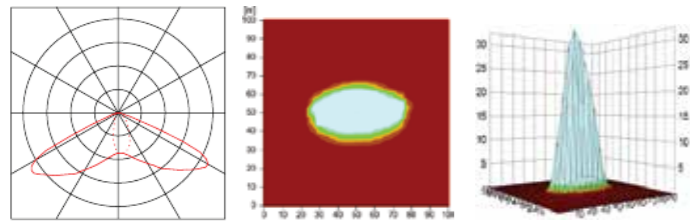

Specification

모델명 Model name	물품식별번호 G2B	전력 Power consumption	광효율 Luminous efficiency	연색성 CRI	색온도 Color temperature	인증 Certification	금액 Unit price
SKL-16BA-2502KS	22997602	25W	95이상	75이상	5000K	☞	250,000
SKL-16BA-2502KG	23040718	25W	119	81	5000K	☞☞☞☞☞☞☞☞	301,000

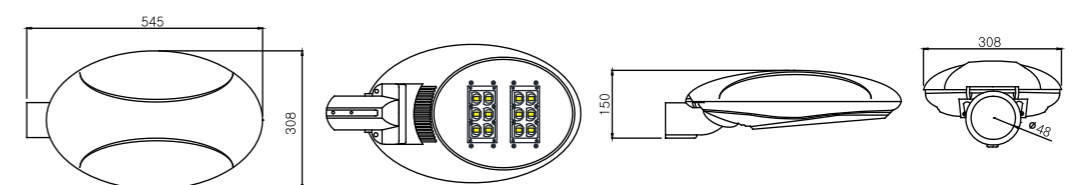

Description

모듈형 파워엘이디의 강력한 직진성의 특징을 살려 설치 위치에 따라 화려한 조명을 연출한다.
고효율제품으로 현장상황에 적절한 온전한 밝기 실현과 눈부심 없는 안전한 보안등기구임.
자연의 빛에 가까운 엘이디조명의 특성을 십분 활용한 정교한 연출이 필요한곳에 적절한 보안등기구임.

직하조도 / 배광곡선

Test. 50m x 50m x 3m SKL-16BA-5002KG

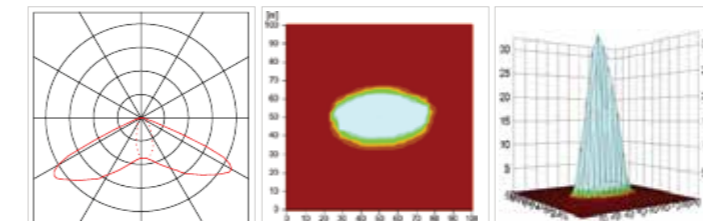

Specification

모델명 Model name	물품식별번호 G2B	전력 Power consumption	광효율 Luminous efficiency	연색성 CRI	색온도 Color temperature	인증 Certification	금액 Unit price
SKL-16BA-5002KS	22997603	50W	95이상	75이상	5000K	☞	350,000
SKL-16BA-5002KG	23040719	50W	117	82	5000K	☞☞☞☞☞☞☞☞	369,000

LED 보안등 SKL-16BA-5004KS

G2B물품식별번호 23129074

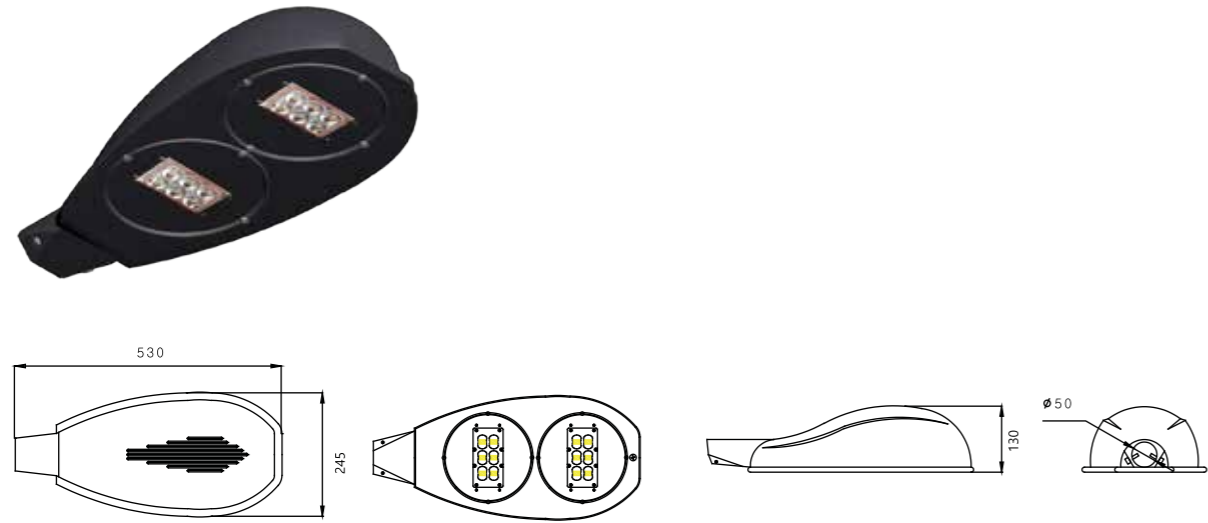

Description

- 광원 기판 360°회전 + 모듈 좌우회전 : 빛 방향 + 조사각 자유제어
- 유실되는 빛 차단, 효율적인 빛 활용
- 빛 공해 차단기능 : 건물, 농경지 등에 침투하는 빛 차단

적하조도 / 배광곡선

Test. 100m x 100m x 5m SKL-16BA-5004KS

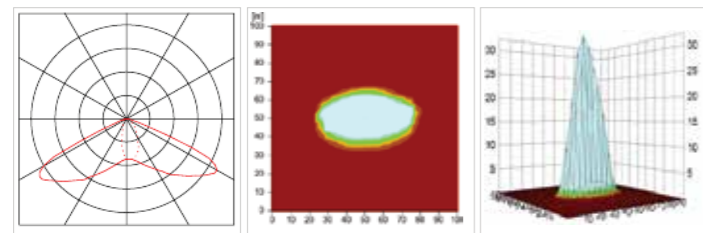

Specification

모델명 Model name	물품식별번호 G2B	전력 Power consumption	광효율 Luminous efficiency	연색성 CRI	색온도 Color temperature	인증 Certification	금액 Unit price
SKL-16BA-5004KS	23129074	50W	124	78	5000K		280,000

LED 보안등 SKLED-13BA-6000KG

G2B물품식별번호 22652752



Description

- 소형 경량의 심플 컷오프형 보안등기구임.
- 경관 및 보안등기구 최적의 광량을 발휘하여 편안한 조명을 연출한다.

적하조도 / 배광곡선

Test. 100m x 100m x 5m SKLED-13BA-6000KG

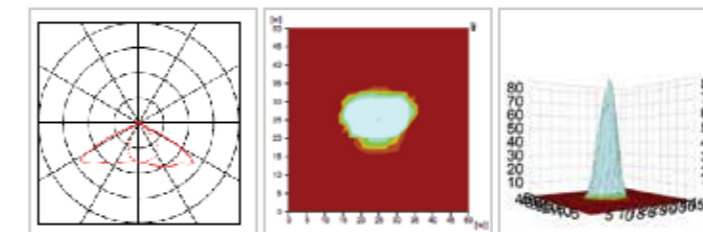

Specification

모델명 Model name	물품식별번호 G2B	전력 Power consumption	광효율 Luminous efficiency	연색성 CRI	색온도 Color temperature	인증 Certification	금액 Unit price
SKLED-13BA-4001KG	22661769	40W	118	78	5700K		400,000
SKLED-13BA-6001KG	22661768	60W	114	78	5700K		462,000
SKLED-13BA-6000KG	22652752	60W	107	79	5700K		549,000

LED 포커스 모듈 보안등 SKL-15BA-5001KG

G2B물품식별번호 22989671

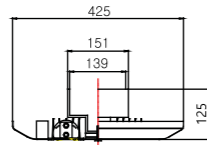
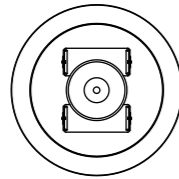
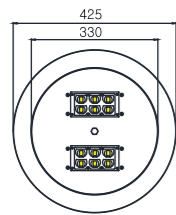

Description

모듈형 파워엘이디의 강렬한 직진성의 특징을 살려 설치 위치에 따라 화려한 조명을 연출한다. 모듈 각각 좌우회전 가능케 한 구조로 필요부분을 집중조명할 수 있도록 함으로 이상적인 배광을 실행함과 동시에 빛의 사각지대가 없도록 설계하였다. 자연의 빛에 가까운 엘이디조명의 특성을 심분 활용한 정교한 연출이 필요한곳에 적절한 보안등기구임. 기존 하향설치된 글로브등기구 (MH램프)를 모듈형 LED등기구로 손쉽게 설치가 될수 있게 설계된 제품이다.

직하조도 / 배광곡선

Test. 50m x 50m x 3m SKL-15BA-5001KG

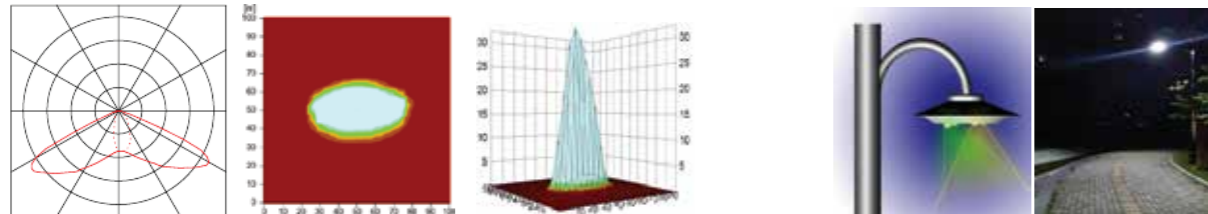

Specification

모델명 Model name	물품식별번호 G2B	전력 Power consumption	광효율 Luminous efficiency	연색성 CRI	색온도 Color temperature	인증 Certification	금액 Unit price
SKL-15BA-2501KG	22989670	25W	120	80	5700K		201,000
SKL-15BA-5001KG	22989671	50W	130	82	5700K		289,000

LED 옥타곤 보안등 SKLED-14BA-6004KS

G2B물품식별번호 22729382

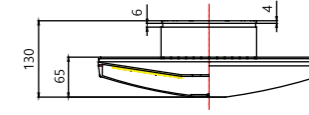
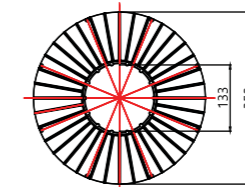
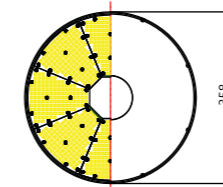
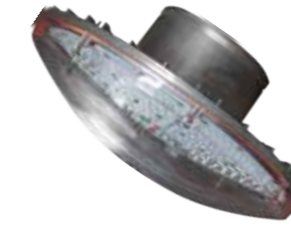
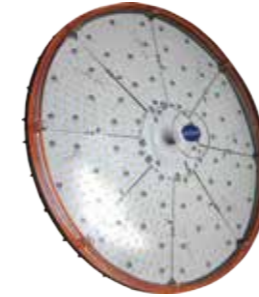

Description

8조각면이 중앙하향경사각구조광원으로 8조각면이 중앙에 모여 아래로 쏘는 형태로서 배광범위 가장 이상적임. 동급 등기구 대비 월등한 광효율. 눈부심 적은 저W LED소자사용 고효율제품

직하조도 / 배광곡선

Test. 100m x 100m x 5m SKL-14BA-6004KS

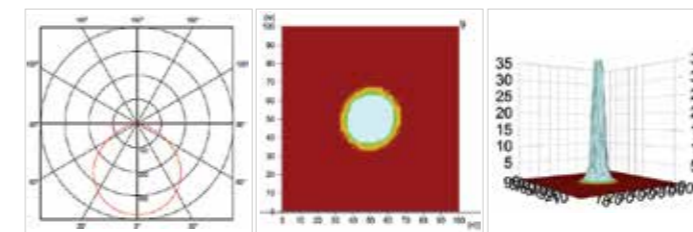

Specification

모델명 Model name	물품식별번호 G2B	전력 Power consumption	광효율 Luminous efficiency	연색성 CRI	색온도 Color temperature	인증 Certification	금액 Unit price
SKLED-14BA-6004KS	22729382	60W	111	88	5700K		290,000

LED 옥타곤 보안등 SKLED-14BA-6005KS

G2B물품식별번호 22729383



LED 보안등 SKL-15BA-6001KS

G2B물품식별번호 22866184

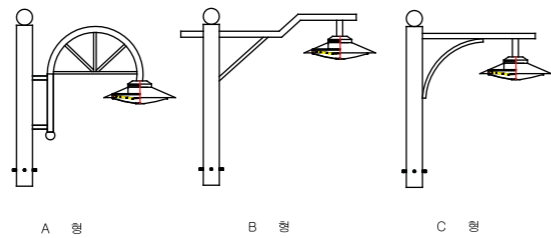
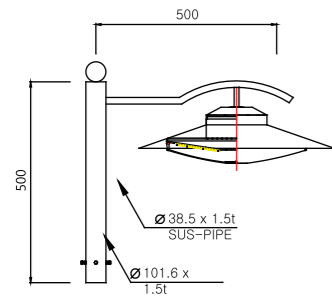

Description

8조각면이 중앙하향경사각구조광원으로 8조각면이 중앙에 모여 아래로 쏘는 형태로서 배광범위 가장 이상적임.
동급 등기구 대비 월등한 광효율.
눈부심 적은 저W LED소자사용 고효율제품

직하조도 / 배광곡선

Test. 100m x 100m x 5m SKLED-14BA-6005KS

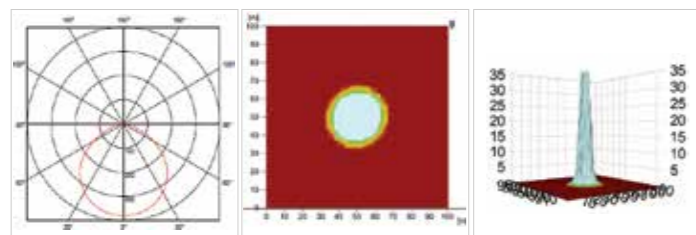

Specification

모델명 Model name	물품식별번호 G2B	전력 Power consumption	광효율 Luminous efficiency	연색성 CRI	색온도 Color temperature	인증 Certification	금액 Unit price
SKLED-14BA-6005KS	22729383	60W	95이상	75이상	5700K	☞	490,000

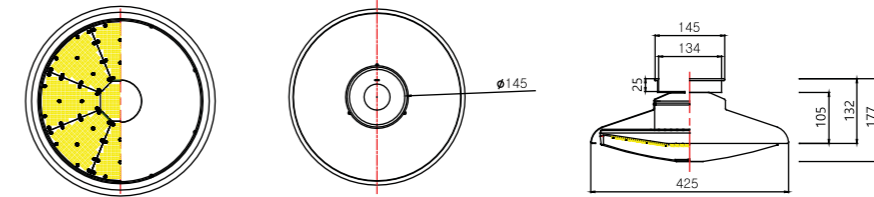

Description

백색파워엘이디의 화려하고 강한 직진성의 특성을 100% 활용, 8조각면을 중앙하향경사각으로 배치하여 8조각면이 중앙에 모여 아래로 쏘는 형태로서 배광범위 가장 이상적임. 동급 등기구 대비 월등한 광효율을 자랑함.
일반 메탈 갓등의 램프결합구조를 그대로 응용조립한 구조로서, 간단 교체결합 가능

직하조도 / 배광곡선

Test. 100m x 100m x 5m SKL-15BA-6001KS

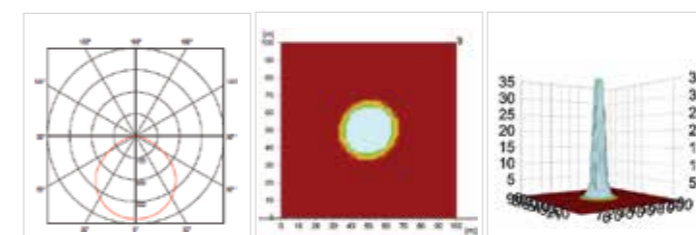

Specification

모델명 Model name	물품식별번호 G2B	전력 Power consumption	광효율 Luminous efficiency	연색성 CRI	색온도 Color temperature	인증 Certification	금액 Unit price
SKL-15BA-6001KS	22866184	60W	95이상	75이상	5700K	☞	310,000

LED UFO 보안등 하향 SKL-17BA-3501KS

G2B물품식별번호 23225074



LED UFO 보안등 SKL-16BA-6007KG

G2B물품식별번호 23129075

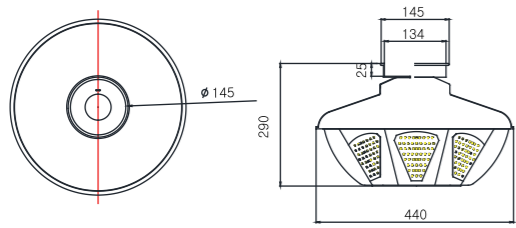
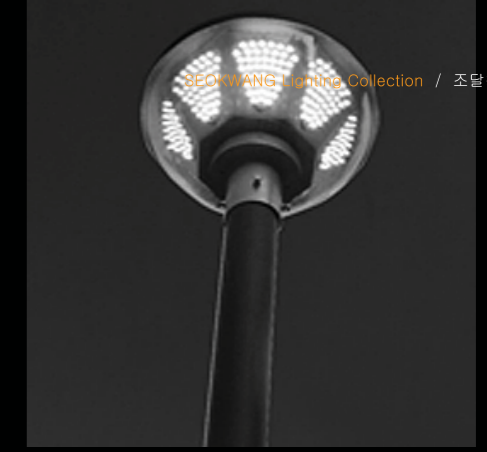

Description

파워엘이디의 화려하고 강한 직진성의 특성을 100% 활용 8조각면이 중앙하향경사각구조광원으로 8조각면의 중앙하향모듬식 구조로서 배광범위 가장 이상적임. 동급 등기구 대비 월등한 광효율을 자랑함과 동시에 미려한 광원색으로 세련된 야간경관 조명을 연출함.

작하조도 / 배광곡선

Test. 50m x 50m x 3m SKL-17BA-3501KS

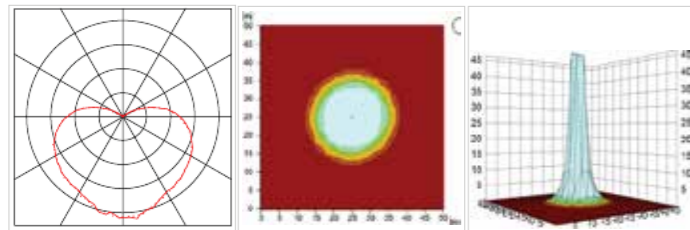

Specification

모델명 Model name	물품식별번호 G2B	전력 Power consumption	광효율 Luminous efficiency	연색성 CRI	색온도 Color temperature	인증 Certification	금액 Unit price
SKL-17BA-3501KS	23225074	35W	120	85	5700K	☞☞	350,000
SKL-17BA-3502KS	23225075	35W	120	84	3000K	☞☞	350,000
SKL-17BA-6001KS	23225076	60W	112	86	3000K	☞☞	390,000

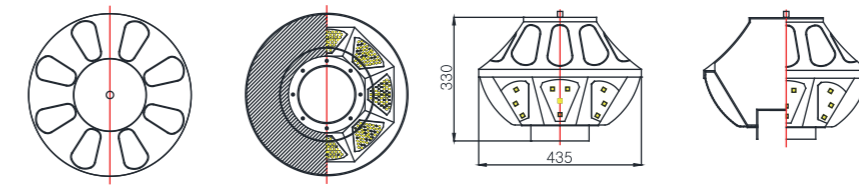

Description

8조각면 하향광원 구조로 빛의 활용도 100%로 배광범위 가장 이상적임. 사각지대 없이 주변 선명. 완벽한 방습 깃(덮개) 구조로 방진, 방수. 눈부심 적은 저W LED소자사용 고효율제품

작하조도 / 배광곡선

Test. 50m x 50m x 3m SKL-16BA-6007KG

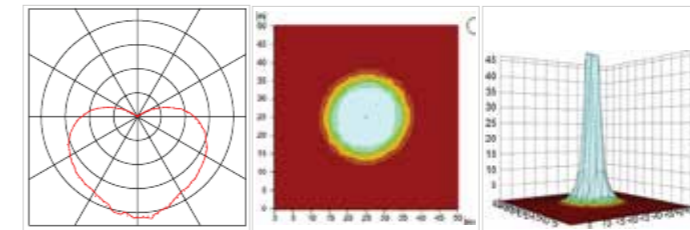

Specification

모델명 Model name	물품식별번호 G2B	전력 Power consumption	광효율 Luminous efficiency	연색성 CRI	색온도 Color temperature	인증 Certification	금액 Unit price
SKL-14BA-6001KS	22789415	60W	125	87	5700K	☞☞	390,000
SKL-16BA-6007KG	23129075	60W	134	80	5700K	☞☞☞☞☞☞	445,000

LED 노블(Noblesse) 보안등 SKL-15BA-6004KS

G2B물품식별번호 22986566



LED 보안등 SKLED-14BA-6002KS

G2B물품식별번호 22729380

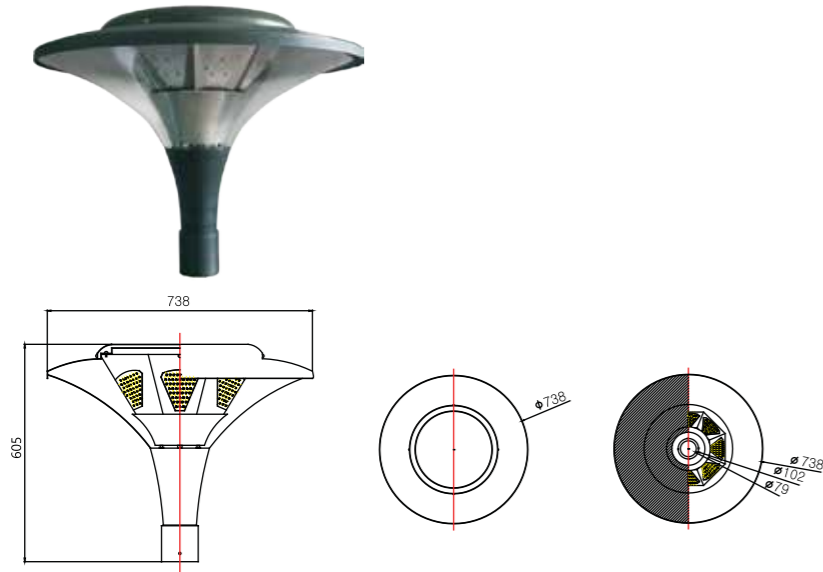

Description

8조각면 하향광원 구조로 빛의 활용도 100%로 배광범위 가장 이상적임. 사각지대 없이 주변 선명. 건물 2~3층부분으로 비추는 빔공해 차단구조임. 외관이 미려하고 백색의 화려한 엘이디조명의 완벽한 조합으로 아름다운 경관을 연출함.

직하조도 / 배광곡선

Test. 100m x 100m x 5m SKL-15BA-6004KS

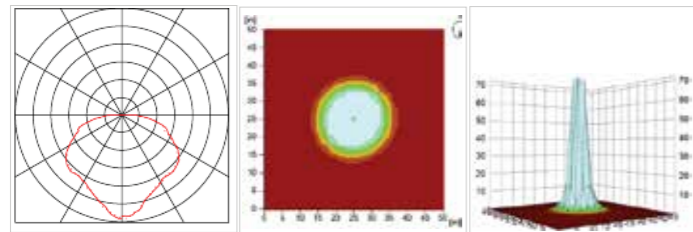

Specification

모델명 Model name	물품식별번호 G2B	전력 Power consumption	광효율 Luminous efficiency	연색성 CRI	색온도 Color temperature	인증 Certification	금액 Unit price
SKL-15BA-6004KS	22986566	60W	122	87	5700K		650,000

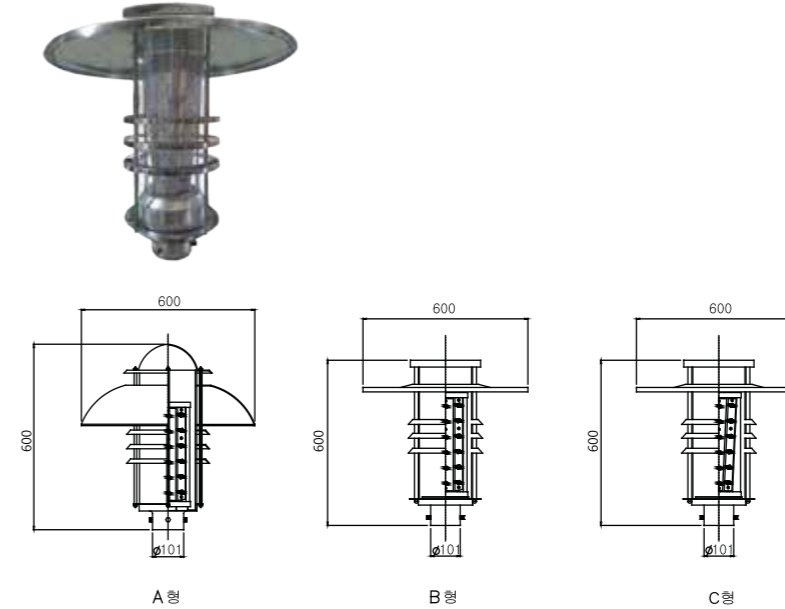

Description

A형 : 완만한 원형 갓+ LED모듈, B형 : 슬림갓+LED 모듈, C형 : 슬림갓+ 하향 경사각형 LED모듈(하부가 차차 좁아지는 형태임)의 각 특색을 지닌 형태로서 엘이디의 강렬한 직진성의 특징을 살리고 이에 경관조명 최적의 광량을 발휘하도록 효율적인 모듈 배치형 조명으로 타워형 최적의 보안등기구임.

직하조도 / 배광곡선

Test. 100m x 100m x 5m SKL-14BA-6002KS

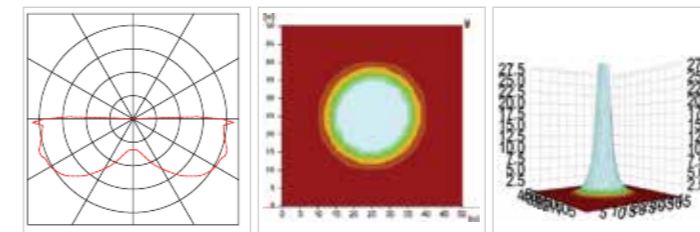

Specification

모델명 Model name	물품식별번호 G2B	전력 Power consumption	광효율 Luminous efficiency	연색성 CRI	색온도 Color temperature	인증 Certification	금액 Unit price
SKLED-14BA-6002KS	22729380	60W	95이상	75이상	5700K		450,000

LED 보안등 SKL-18BA-5001KS

G2B물품식별번호 23372619

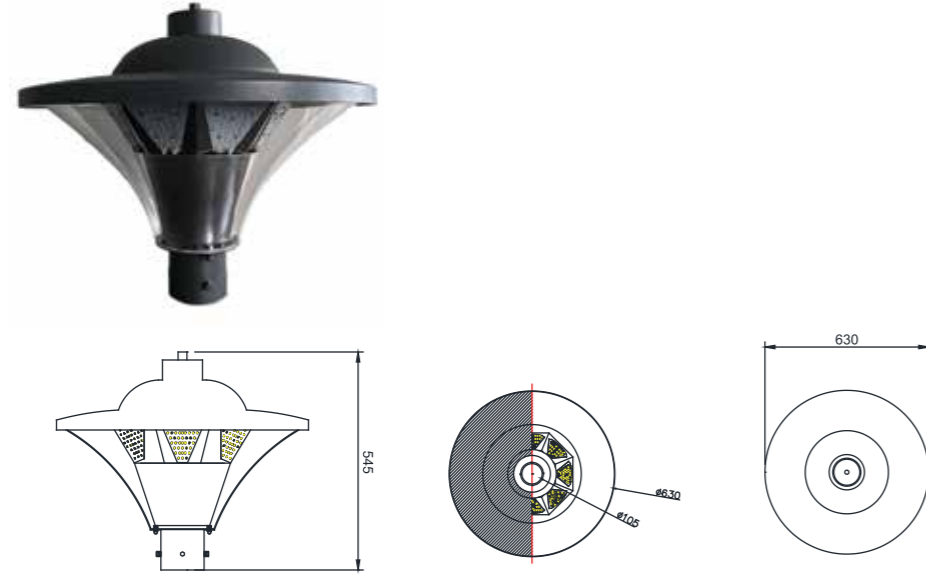

Description

8조각면 하향광원 구조로 빛의 활용도 100%로 배광범위 가장 이상적임. 사각지대 없이 주변 선명, 건물 2~3층부분으로 비추는 빛공해 차단구조임. 외관이 미려하고 백색의 화려한 엘이디조명의 완벽한 조합으로 아름다운 경관을 연출함.

작하조도 / 배광곡선

Test. 50m x 50m x 3m SKL-18BA-5001KS

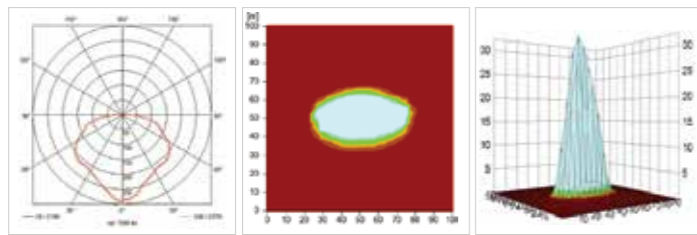

Specification

모델명 Model name	물품식별번호 G2B	전력 Power consumption	광효율 Luminous efficiency	연색성 CRI	색온도 Color temperature	인증 Certification	금액 Unit price
SKL-18BA-5001KS	23372619	50W	95이상	75이상	5700K	☞	

LED 보안등 SKL-18BA-3501KS

G2B물품식별번호

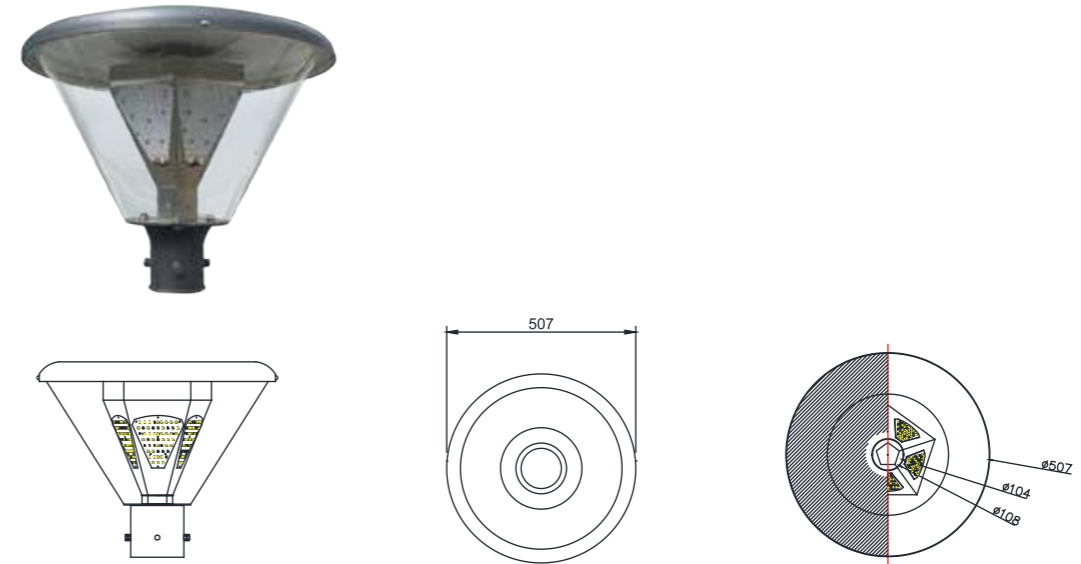

Description

5조각면 하향광원 구조로 빛의 활용도 100%로 배광범위 가장 이상적임. 사각지대 없이 주변 선명, 외관이 미려하고 백색의 화려한 엘이디조명의 완벽한 조합으로 아름다운 경관을 연출함.

작하조도 / 배광곡선

Test. 40m x 40m x 4m SKL-18BA-3501KS

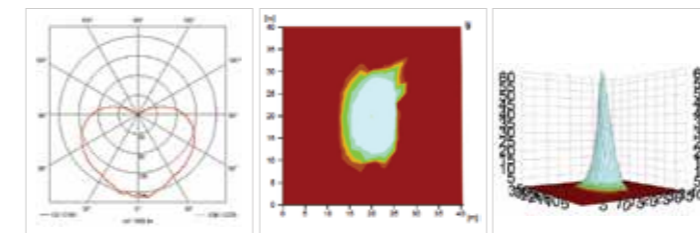

Specification

모델명 Model name	물품식별번호 G2B	전력 Power consumption	광효율 Luminous efficiency	연색성 CRI	색온도 Color temperature	인증 Certification	금액 Unit price
SKL-18BA-3501KS		35W	95이상	75이상	5700K	☞	

LED 모듈 보안등 SKL-17BA-6002KS

G2B물품식별번호 23246750

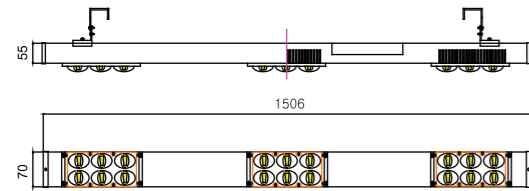

Description

—자 모듈형 등기구로서 모듈의 탈부착, 추가 등이 가능하여 필요한 밝기를 자유로이 연출하게 하였으며, 어떠한 장소에서든 가로세로 자유로이 설치가능케 하였음.

직하조도 / 배광곡선

Test. 50m x 50m x 3m SKL-17BA-6002KS

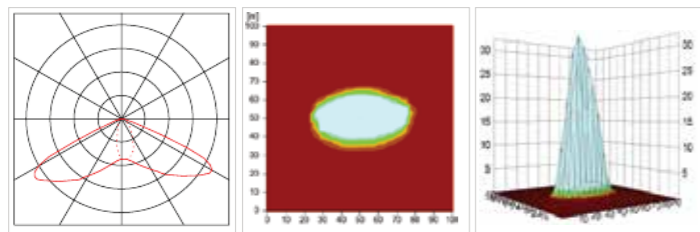

Specification

모델명 Model name	물품식별번호 G2B	전력 Power consumption	광효율 Luminous efficiency	연색성 CRI	색온도 Color temperature	인증 Certification	금액 Unit price
SKL-17BA-6002KS	23246750	60W	135	78	5000K		449,000

LED 청사초롱 보안등 SKL-16BA-2503KS

G2B물품식별번호 23009139

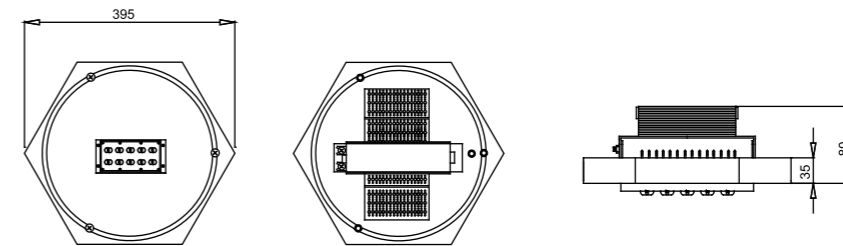

Description

청사초롱 등기구는 민족고유의 전통미를 갖춘 등기구이다. 그러나 등기구 프레임 안에 갇힌 MH 또는 LED램프빛의 확산의 한계성으로 인해 W수가 높은 고소비전력램프를 사용하게 되고 그에 따라 전력비도 상승하게 되나 프레임 안에 갇힌 램프구조상 도로조명으로서 표준조도수치를 충족시키기 어렵다. 이를 개선, 보완한 LED모듈을 청사초롱 등기구 저변에 부착시킴으로써 전통미를 살리고 표준조도를 넉넉히 충족시켜 1석2조의 효과를 얻게한다.

직하조도 / 배광곡선

Test. 40m x 40m x 4m SKL-16BA-2503KS

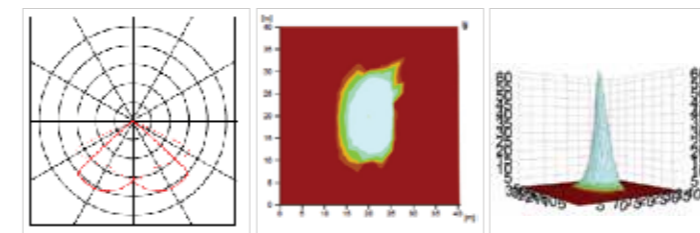

Specification

모델명 Model name	물품식별번호 G2B	전력 Power consumption	광효율 Luminous efficiency	연색성 CRI	색온도 Color temperature	인증 Certification	금액 Unit price
SKL-16BA-2503KS	23009139	25W	95이상	75이상	5000K		270,000

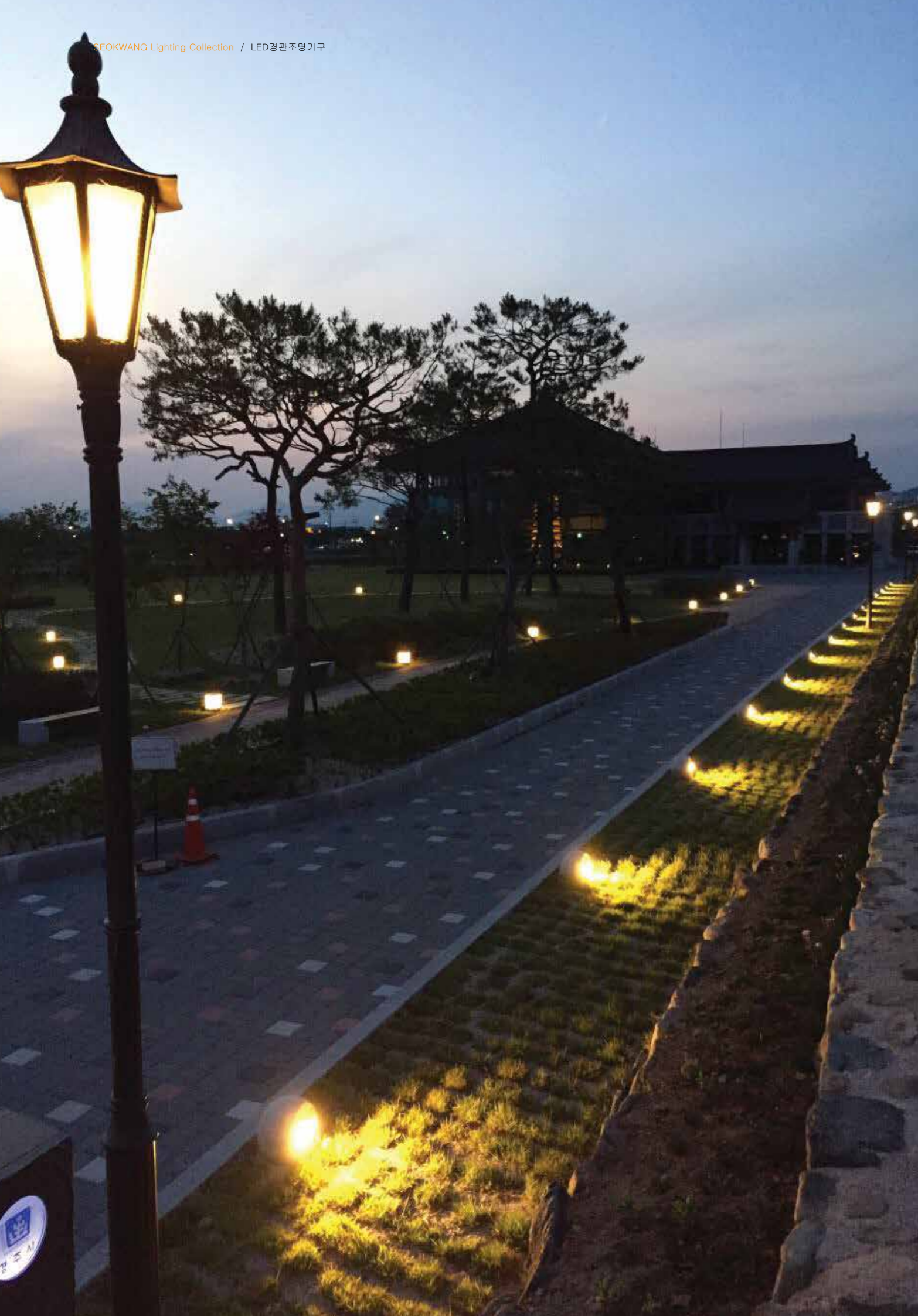

처음부터
담장의 일부인듯
어우러져 주야간 경관을 아름답게 살리는
최고의 품질과 미려한 디자인의 돌투광기는
서광조명 경관LED의 명품제품으로 자랑하는 제품이다.



LED 경관조명 SKL-15GK-2000KS

G2B물품식별번호 22870870

가격 : 920,000원



석재 LED20W

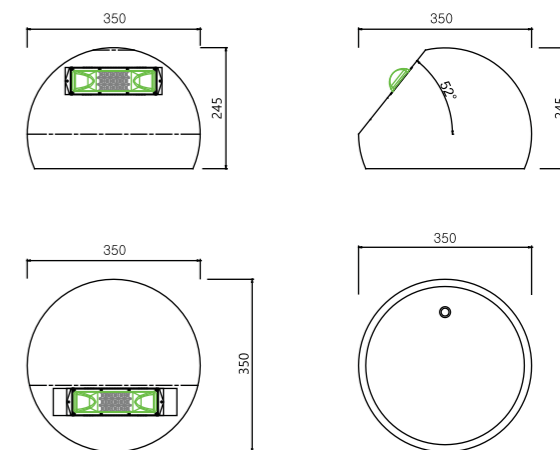



LED 경관조명 SKL-15GK-2001KS

G2B물품식별번호 22870871

가격:910,000원



석재 LED20W

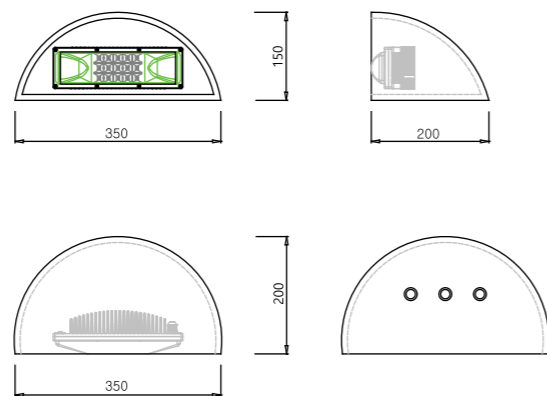

LED 경관조명 SKL-15GK-2002KS

G2B물품식별번호 22878752

가격:450,000원



AL LED20W

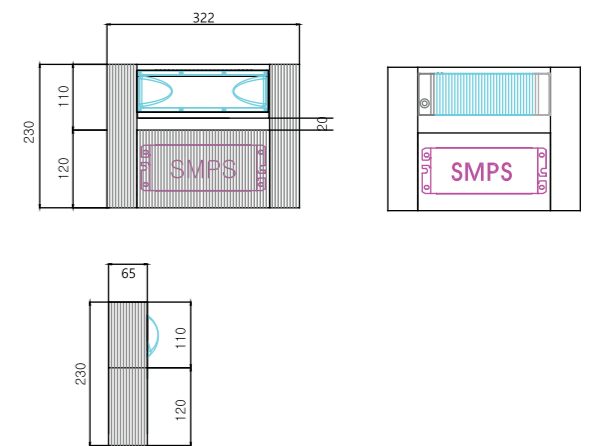



LED 경관조명 SKL-14GK-1200KS

G2B물품식별번호 22808227
가격 : 350,000원



Al. Pc 1m
- LED12W

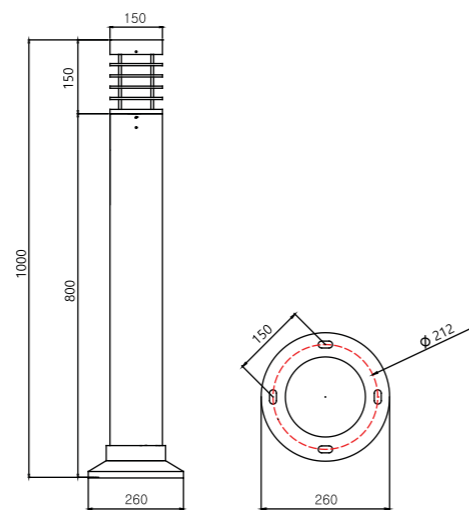

LED 경관조명 SKL-14GK-1201KS

G2B물품식별번호 22808228
가격 : 350,000원



원목. Pc 0.86m
- LED12W

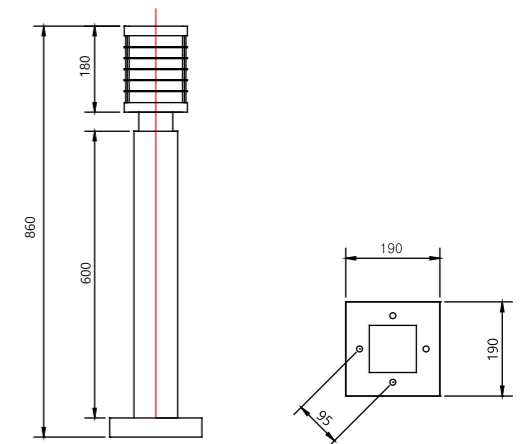



LED 경관조명
SKL-16GK-1500KS

G2B물품식별번호 22976660
가격 : 450,000원



원목. Pc 1m
LED 15W

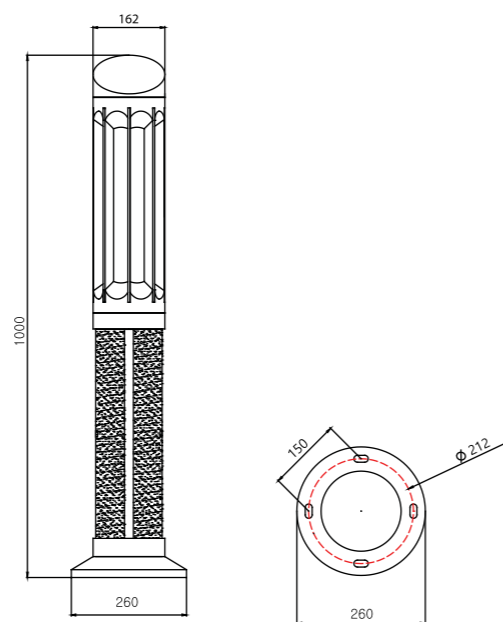

LED 경관조명
SKL-16GK-1501KS

G2B물품식별번호 22986249
가격 : 400,000원



Al. Pc 0.89m
LED15W

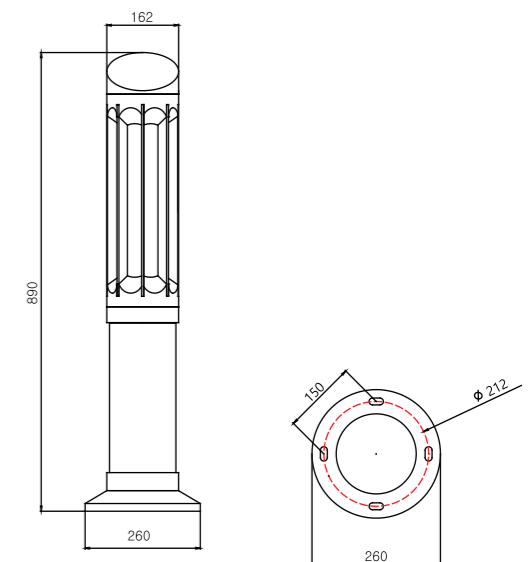



LED 경관조명
SKL-16GK-5000KS
G2B물품식별번호 22981971
가격 : 1,800,000원

LED 경관조명
SKL-16GK-2003KS

G2B물품식별번호 23053714
가격 : 850,000원



STS 0.95m
LED20W

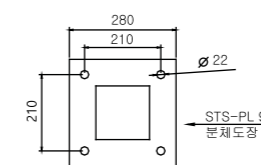
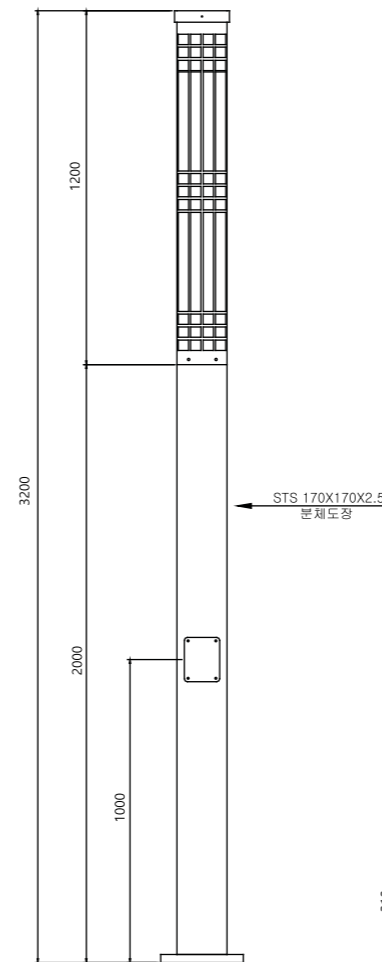
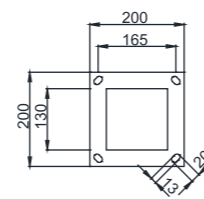
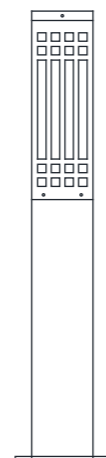
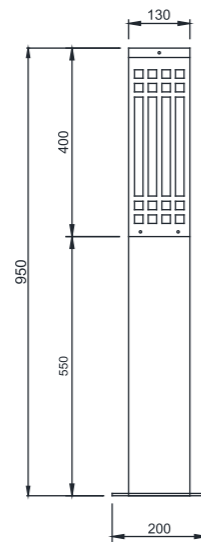

STS 3.2m
LED 50W





LED 경관조명
SKL-14GK-5001KS
 G2B물품식별번호 22808229
 가격 : 1,750,000원



LED 경관조명
SKL-18GK-5000KS

G2B물품식별번호 23372618
 가격 : 850,000원



Al.Pc. 1.3m
 LED 50W

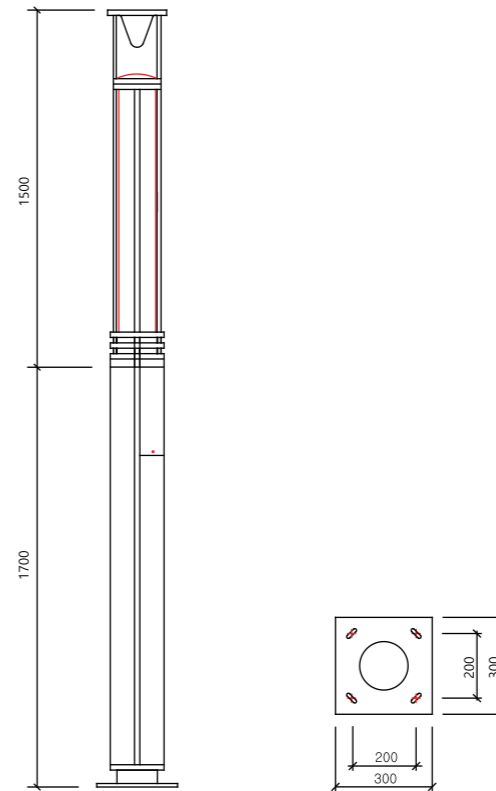
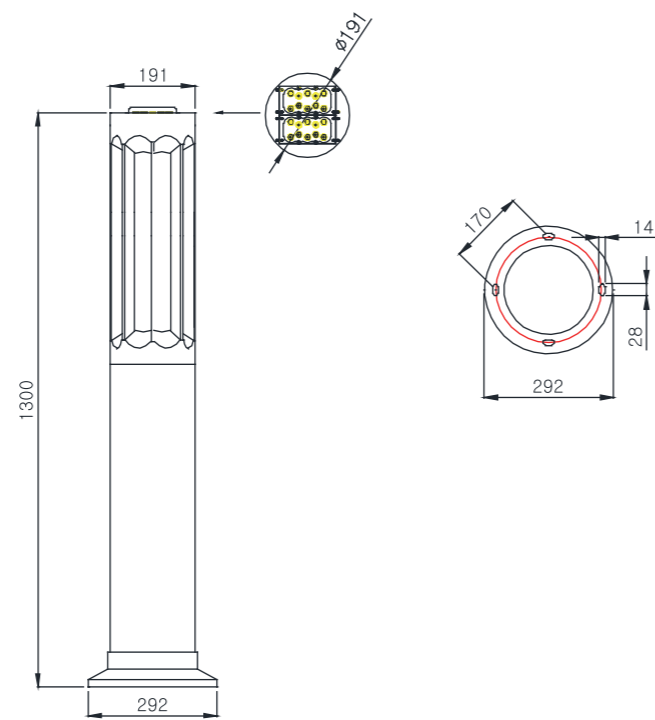

Al.Pc. 3.2m
 LED 50W

LED 경관조명 SKL-14GK-5002KS

G2B물품식별번호 22809813
가격 :1,840,000원



원목. Pc 3.3m
LED 50W

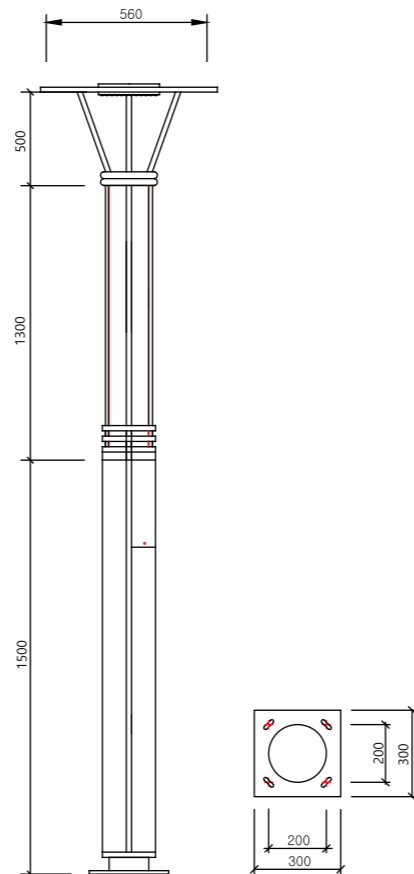

LED 경관조명 SKL-14GK-6000KS

G2B물품식별번호 22808230
가격 :1,800,000원



STS 원목. Pc. 3.9m
LED60W

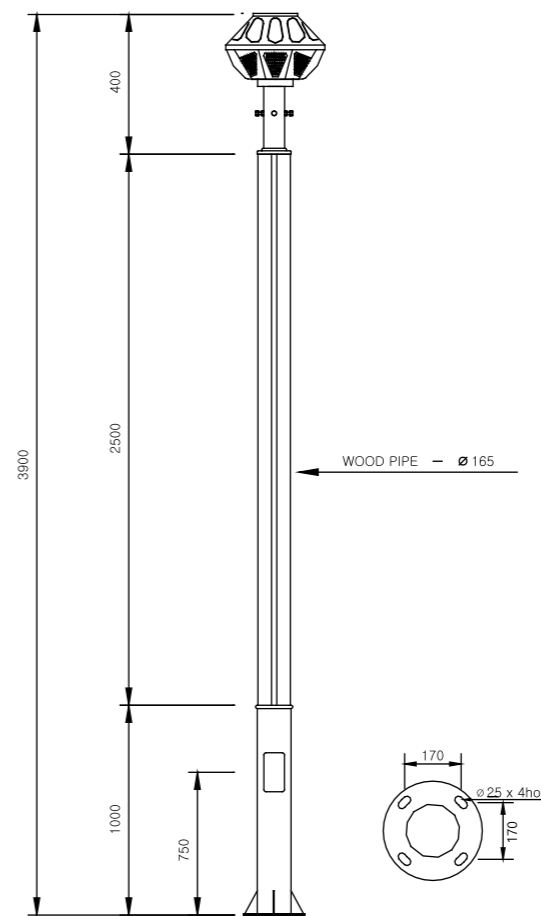

LED 경관조명 SKL-14GK-6001KS

G2B물품식별번호 22808231

가격 :1,900,000원



STS원목 3.9m
LED60W

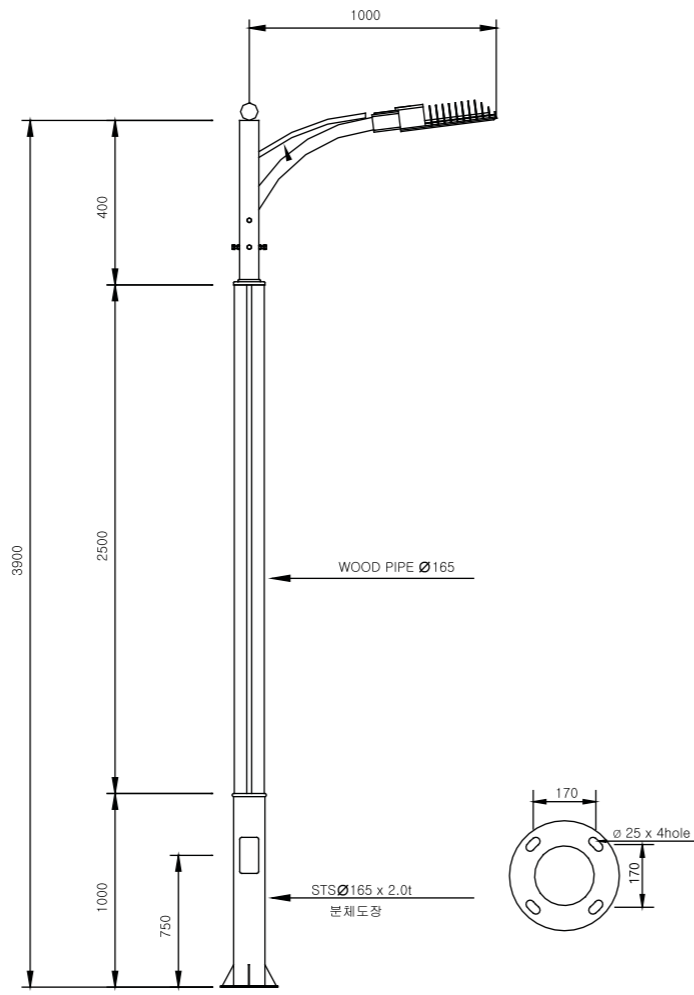

LED 경관조명 SKL-14GK-6021KS

G2B물품식별번호 22808232

가격 :2,300,000원

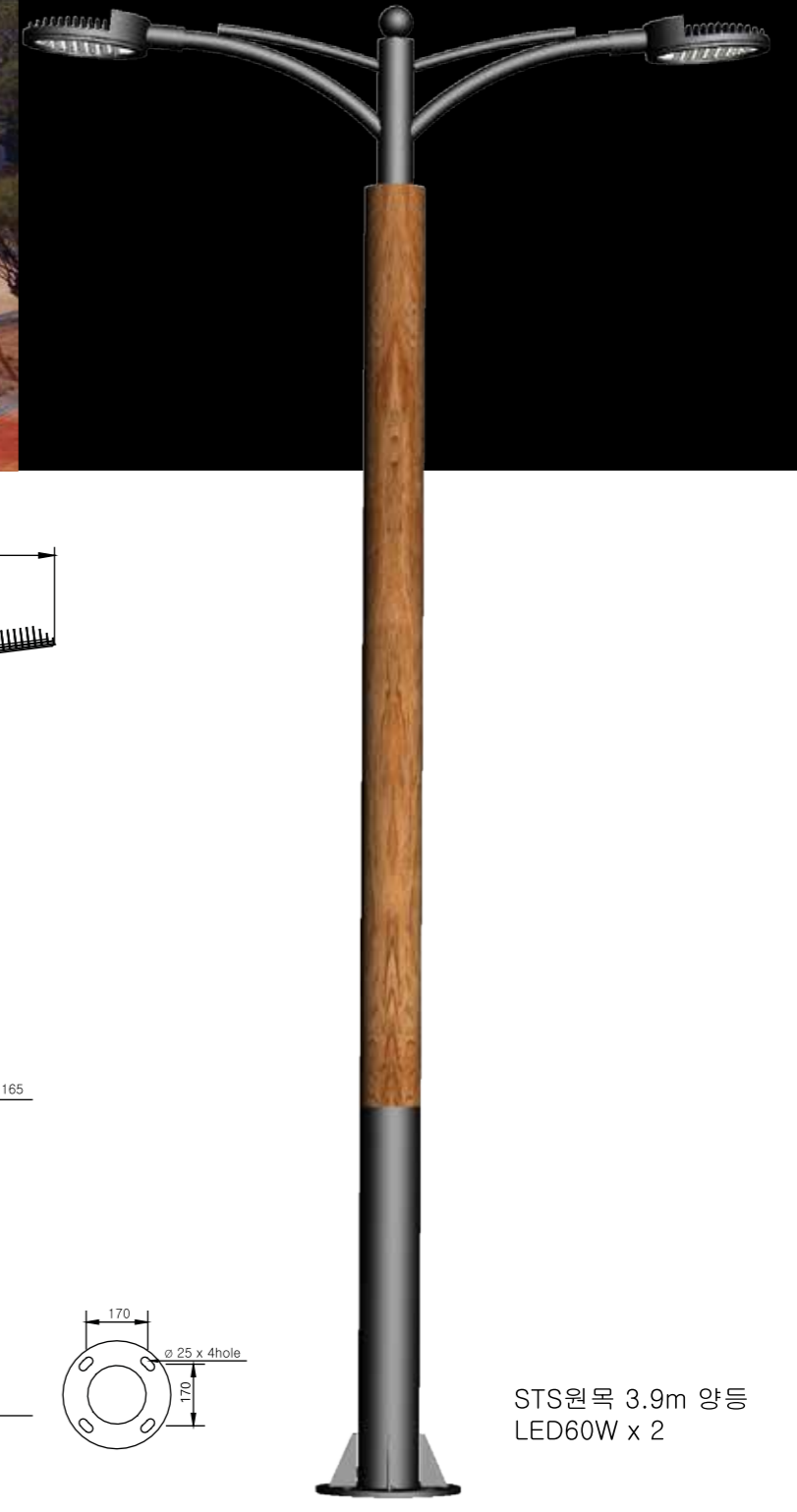

STS원목 3.9m 양등
LED60W x 2

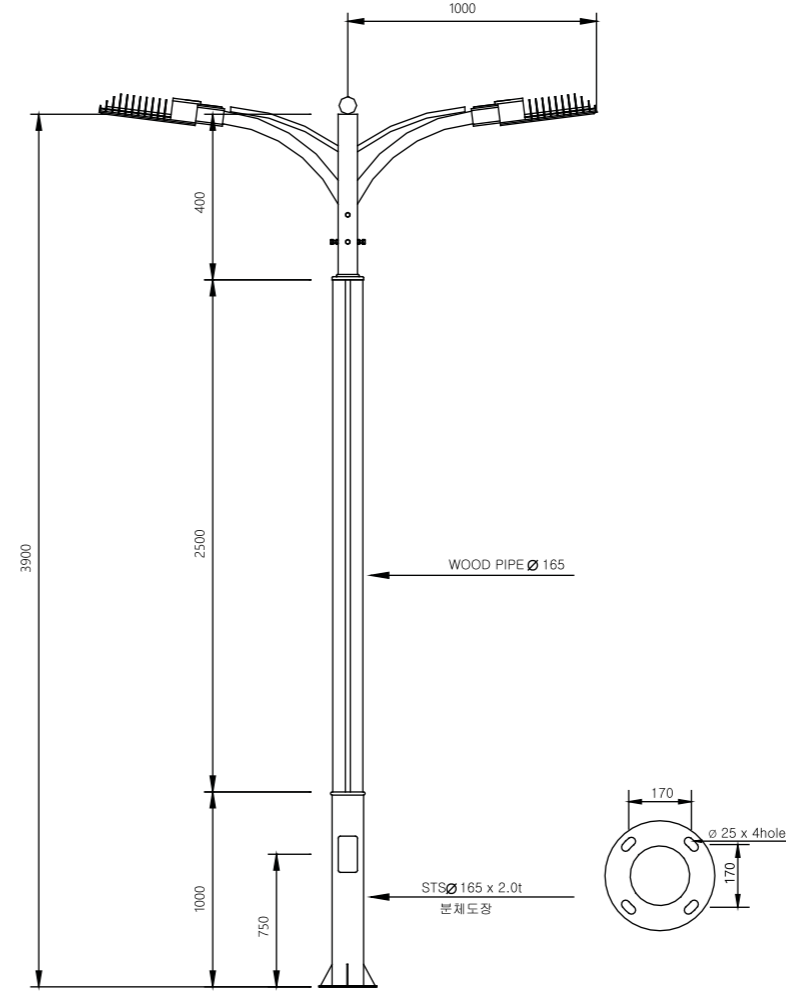

LED 경관조명

SKL-18GK-6002KS

G2B물품식별번호 23478756



STS. PC 3.9m
LED 60W

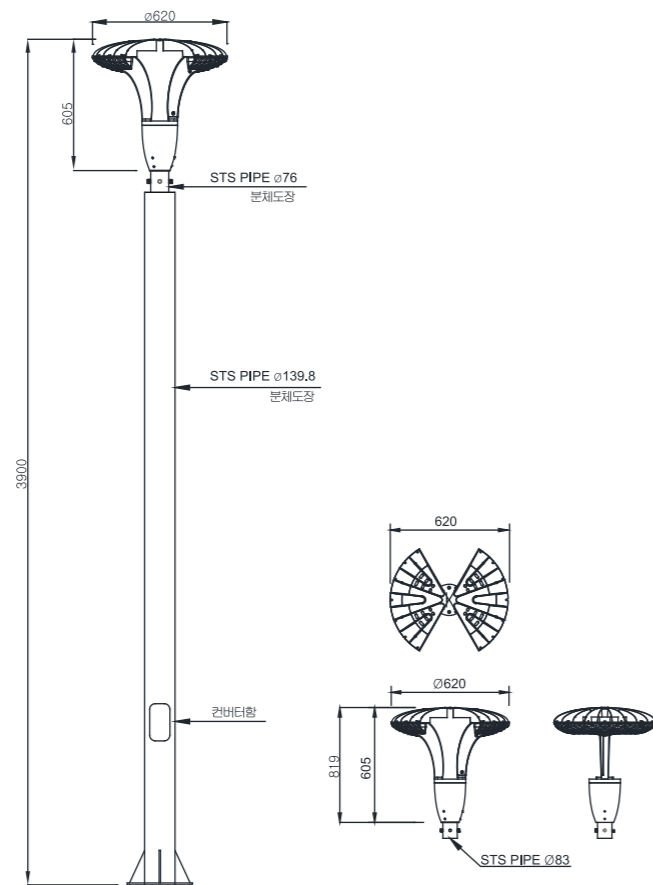

LED 경관조명

SKL-18GK-6001KS

G2B물품식별번호 23478755



LED 60W

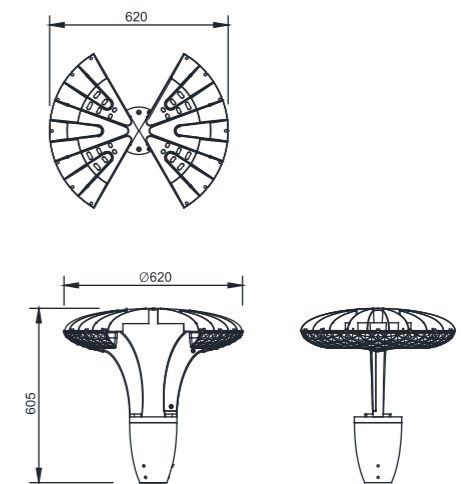



LED 경관조명(청사초롱 모듈형 조명기구)

SKL-16GK-2501KS

G2B물품식별번호 23054743



LED 경관조명

SKL-14GK-9000KS

G2B물품식별번호 22813115

가격 : 730,000원

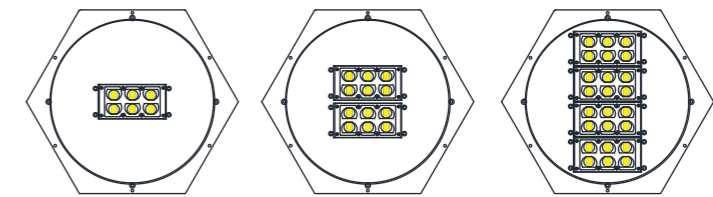
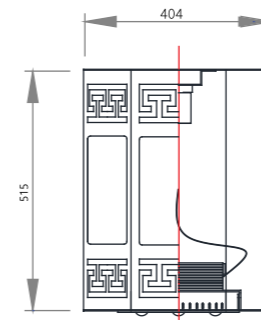
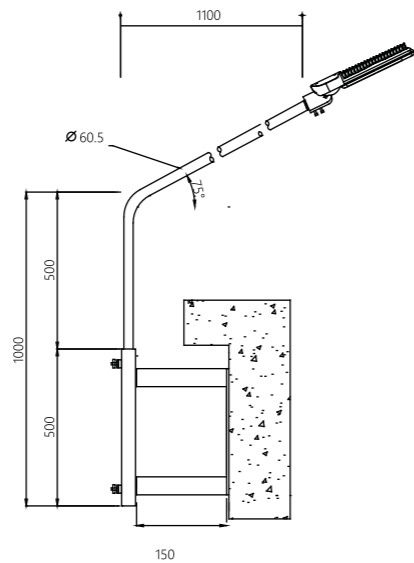

Specification

모델명 Model name	물품식별번호 G2B	전력 Power consumptior	광효율 Luminous efficiency	연색성 CRI	색온도 Color temperature	인증 Certification	금액 Unit price
SKL-16GK-2501KS	23054743	25W	95이상	75이상	5000K	GS	520,000
SKL-16GK-5001KS	23054744	50W	95이상	75이상	5000K	GS	560,000
SKL-16GK-1010KS	23053715	100W	95이상	75이상	5000K	GS	680,000



LED 경관조명 SKL-16GK-2500KS

G2B물품식별번호 22976661
가격 : 200,000원



STS LED25W

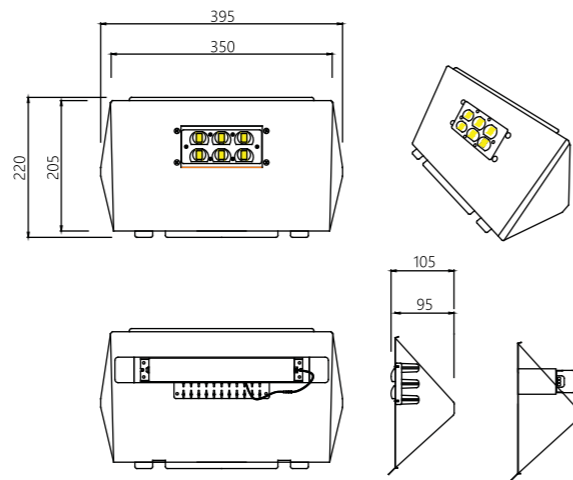

LED 경관조명 SKL-17GK-2500KS

G2B식별번호 23170781
가격:310,000원



LED 25W

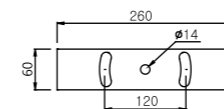
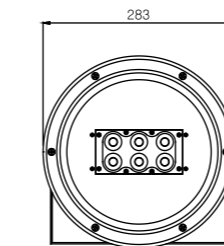

LED 50W

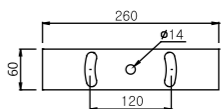
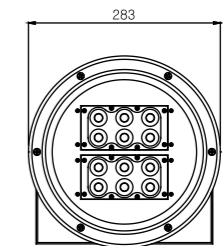

LED 경관조명 SKL-17GK-5000KS

G2B식별번호 23170782
가격:370,000원



LED 경관조명
SKL-18GK-2500KS

G2B식별번호 23450136



STS
LED25W

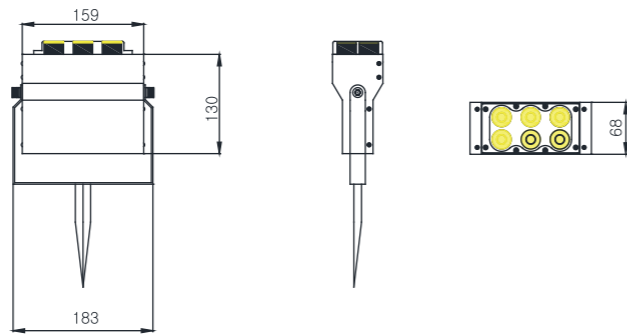

LED 경관조명
SKL-18GK-2501KS

G2B물품식별번호 23472972

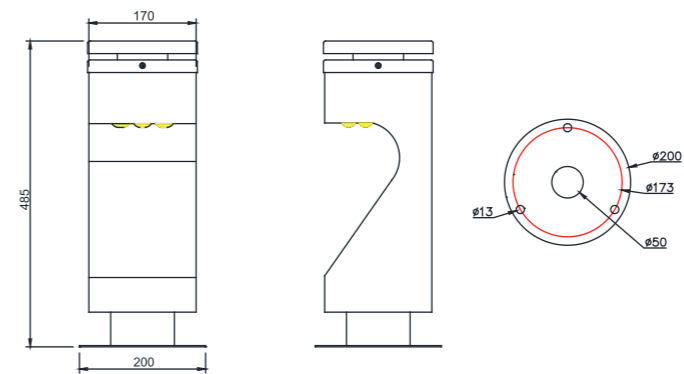

STS
LED25W



LED 경관조명
SKL-18GK-2502KS
 G2B식별번호 23472974



STS
LED25W

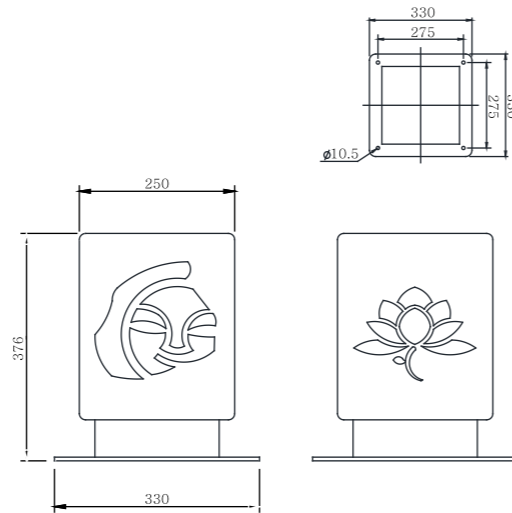

LED 투광조명
SKL-17TK-2500KG
 G2B물품식별번호 23216644



Al Die casting. LED25W

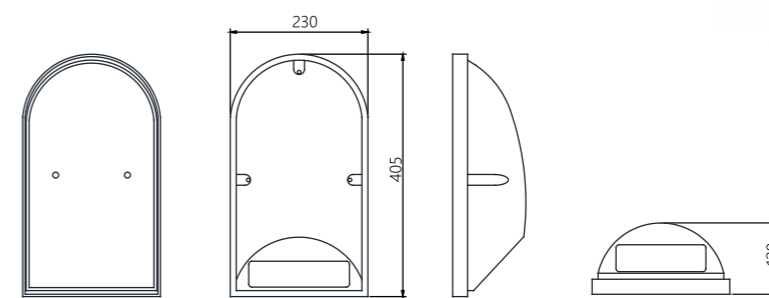

Specification

모델명 Model name	물품식별번호 G2B	전력 Power consumptior	광효율 Luminous efficiency	연색성 CRI	색온도 Color temperature	인증 Certification	금액 Unit price
SKL-17TK-2500KG	23216644	25W	128	75	5000K		187,000

LED 투광등 SKL-17TK-2500KS

G2B식별번호 23168516

LED 투광등 SKL-17TK-5000KS

G2B식별번호 23168517



LED 25W



LED 50W

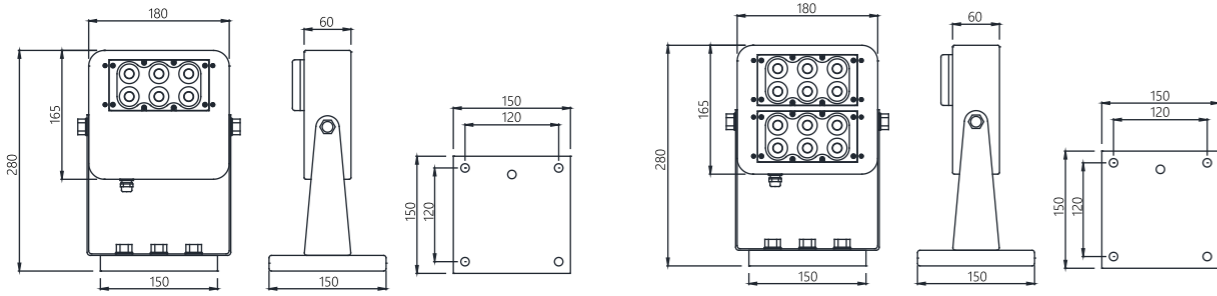

Description

소형 투광등기구로서 과하지 않게 집중 조명할 수 있는 투광기로서 건물외벽, 간판, 외부 조형물, 인테리어 조명 등 다양한 곳에 활용 가능

적하조도 / 배광곡선

Test. 25m x 25m x 3m SKL-17TK-2500KS

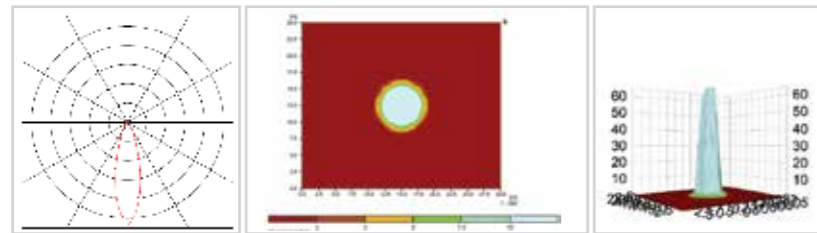

Specification

모델명 Model name	물품식별번호 G2B	전력 Power consumption	광효율 Luminous efficiency	연색성 CRI	색온도 Color temperature	인증 Certification	금액 Unit price
SKL-17TK-2500KS	23168516	25W	95이상	75이상	5000K	☞	240,000
SKL-17TK-5000KS	23168517	50W	95이상	75이상	5000K	☞	340,000



LED 투광등 SKL-17TK-6002KS

G2B식별번호 23261279

LED 투광등 SKL-17TK-8002KS

G2B식별번호 23261281

LED 투광등 SKL-17TK-1011KS

G2B식별번호 23261282



LED 60W



LED 80W



LED 100W

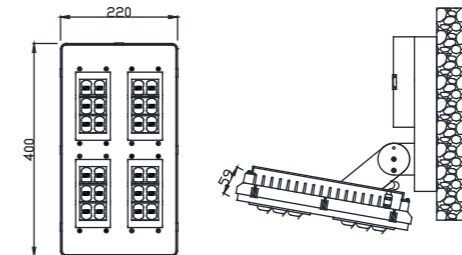

Specification

모델명 Model name	물품식별번호 G2B	전력 Power consumption	광효율 Luminous efficiency	연색성 CRI	색온도 Color temperature	인증 Certification	금액 Unit price
SKL-17TK-6002KS	23261279	60W	95이상	75이상	5000K	☞	470,000
SKL-17TK-8002KS	23261281	80W	137	79	5000K	☞☞	520,000
SKL-17TK-1011KS	23261282	100W	140	79	5000K	☞☞	550,000

LED 투광등 SKL-14TK-1016KS

G2B식별번호 22811705

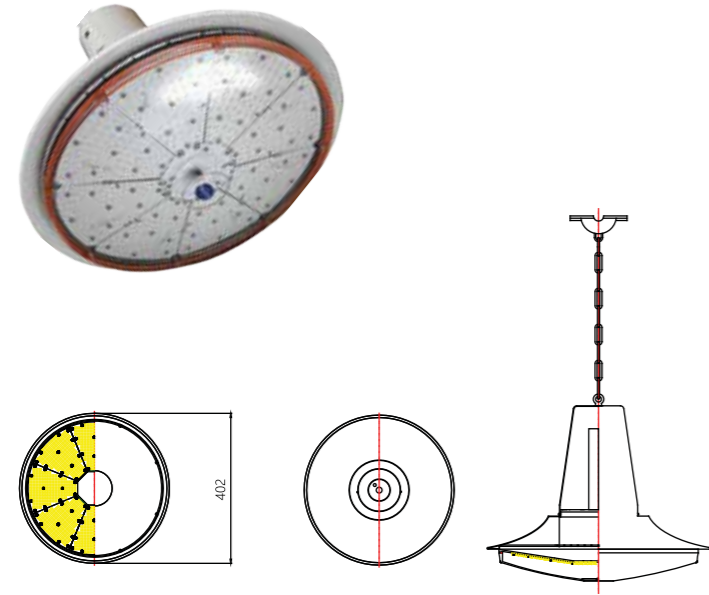

Description

8조각면이 중앙하향경사각구조광원으로 8조각면이 중앙에 모여 아래로 쏘는 형태로서 배광범위 가장 이상적임.
동급 등기구 대비 월등한 광효율,
눈부심 적은 저W LED소자사용 고효율제품

직하조도 / 배광곡선

Test. 10m x 10m x 10m SKL-14TK-1016KS

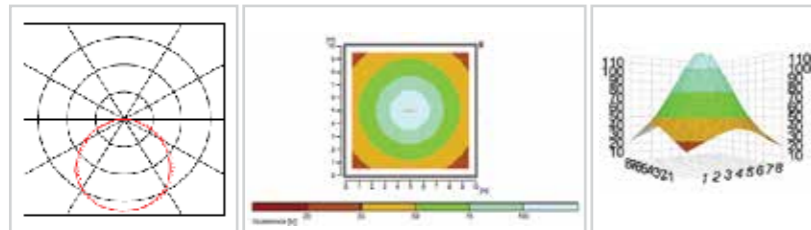

Specification

모델명 Model name	물품식별번호 G2B	전력 Power consumption	광효율 Luminous efficiency	연색성 CRI	색온도 Color temperature	인증 Certification	금액 Unit price
SKL-14TK-1016KS	22811705	100W	133	86	5700K		330,000

LED 투광등 SKL-14TK-1015KS

G2B식별번호 22800754

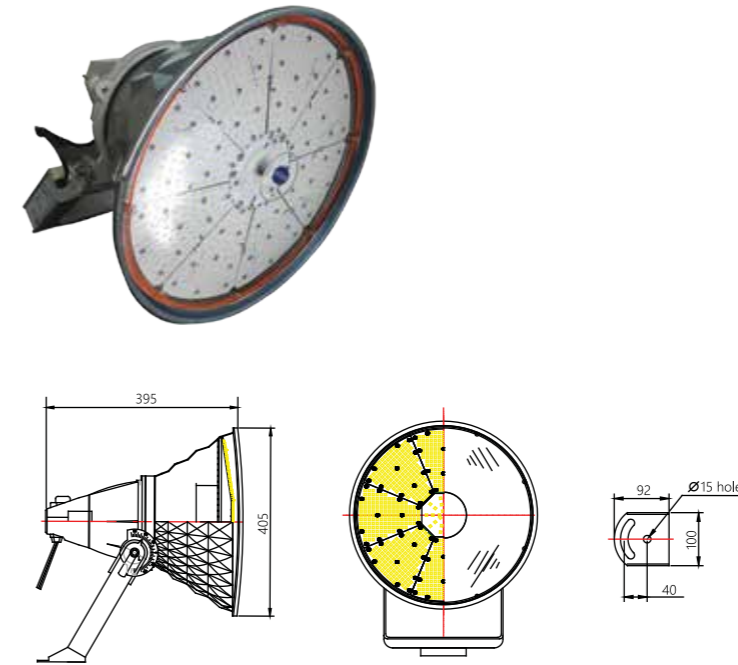

Description

8조각면이 중앙에 모여 중앙부분이 쏘는 형태로서 광 확산효과가 극대화되며, 배광범위 가장 이상적임.
기존의 다이아몬드투광등을 개선하였으며 동급 등기구 대비 월등한 광효율을 자랑함,
눈부심 적은 저W LED소자사용 고효율제품

직하조도 / 배광곡선

Test. 10m x 10m x 10m SKL-14TK-1015KS

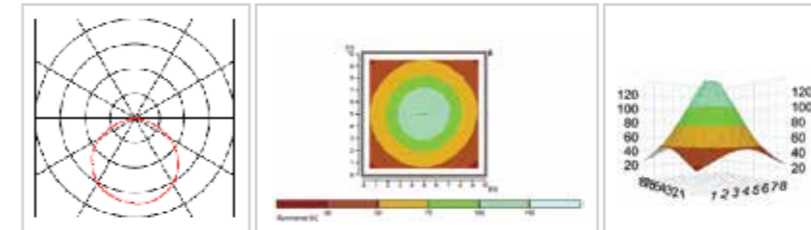

Specification

모델명 Model name	물품식별번호 G2B	전력 Power consumption	광효율 Luminous efficiency	연색성 CRI	색온도 Color temperature	인증 Certification	금액 Unit price
SKL-14TK-1015KS	22800754	100W	109	88	5700K		357,000

LED 투광등 SKL-16TK-1210KS

G2B식별번호 23024527

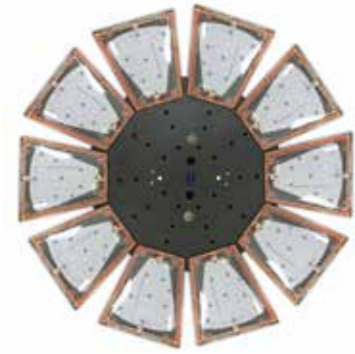

LED 120W

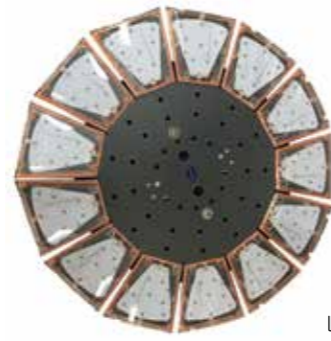

LED 150W

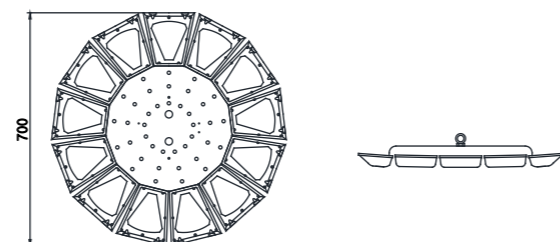
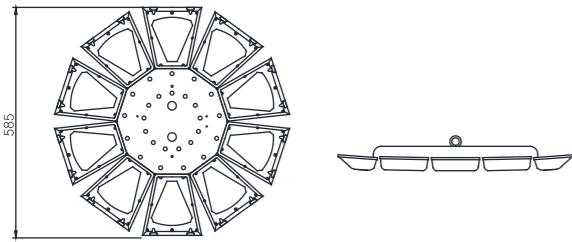

Description

메탈할라이드/고압나트륨/할로겐 대비 50~67% 에너지 절감, 낮은 천정등 9M미만 고W사용시 최적의 분포도 제품임. 경량 슬림형으로 설치 및 유지관리 편리, 높은 광효율로 저비용 고효율 제품임.

직하조도 / 배광곡선

Test. 100m x 100m x 10m SKL-16TK-1210KS

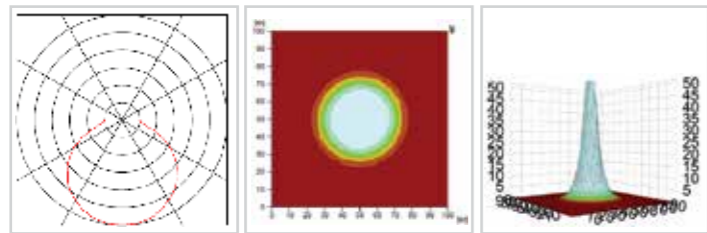

Specification

모델명 Model name	물품식별번호 G2B	전력 Power consumption	광효율 Luminous efficiency	연색성 CRI	색온도 Color temperature	인증 Certification	금액 Unit price
SKL-16TK-1210KS	23024527	120W	95이상	75이상	5700K	☑	430,000
SKL-16TK-1510KS	23024528	150W	95이상	75이상	5700K	☑	450,000

LED 투광등 SKL-16TK-2011KS

G2B식별번호 23100773



LED 200W

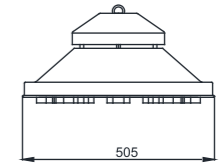
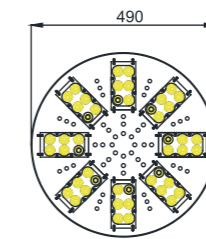
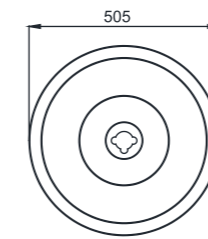

Description

광효율 122lm/w 이상의 8 원형모듈이 코스모스형태로 구성되어 광효율은 극대화되며, 배광범위 가장 이상적임. 전국 초,중,고,대학 체육관 강당 등 국내외 공식경기장용으로 다수 사용됨. 눈부심 적은 LED소자 및 렌즈 사용 고효율제품(7Kg 미만의 경량화된 제품임)

직하조도 / 배광곡선

Test. 100m x 100m x 10m SKL-16TK-2011KS

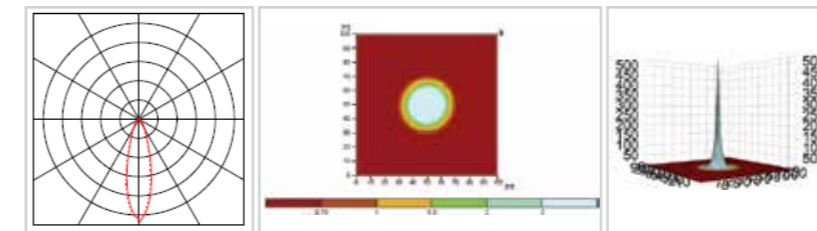

LED 모듈 25W

Specification

모델명 Model name	물품식별번호 G2B	전력 Power consumption	광효율 Luminous efficiency	연색성 CRI	색온도 Color temperature	인증 Certification	금액 Unit price
SKL-18TK-1211KG	23349216	120W	140	81	5000K	☑	557,000
SKL-18TK-1511KG	23349217	150W	132	81	5000K	☑	661,000
SKL-18TK-1811KG	23349215	180W	134	81	5000K	☑	698,000
SKL-16TK-2011KS	23100773	200W	122	76	5000K	☑	748,000

LED 투광등 SKL-14TK-1010KS

G2B식별번호 22790282



LED 투광등 SKL-16TK-2012KS

G2B식별번호 23115628



신성대학교 체육관

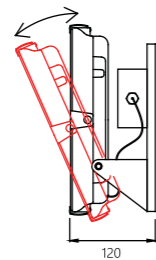
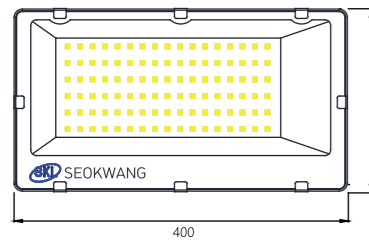

Description

광학산렌즈 사용 : 배광범위 15°, 30°, 60°,
렌즈 없음 : 배광범위 120°

직하조도 / 배광곡선

Test. 30m x 30m x 3m SKL-14TK-1010KS

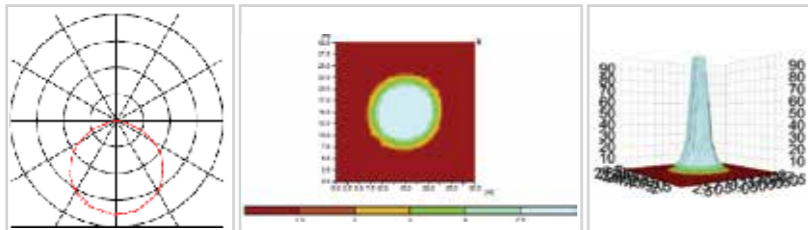

Specification

모델명 Model name	물품식별번호 G2B	전력 Power consumption	광효율 Luminous efficiency	연색성 CRI	색온도 Color temperature	인증 Certification	금액 Unit price
SKL-14TK-4000KG	23007517	40W	125	80	5700K		358,000
SKL-14TK-4000KS	22790279	40W	95이상	75이상	5700K		330,000
SKL-14TK-6000KS	22790280	60W	95이상	75이상	5700K		380,000
SKL-14TK-1010KS	22790282	100W	95이상	75이상	5700K		490,000



SKL-16TK-2012KS LED 200W



SKL-16TK-3010KS LED 300W



SKL-16TK-4011KS LED 400W

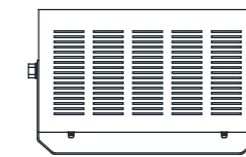
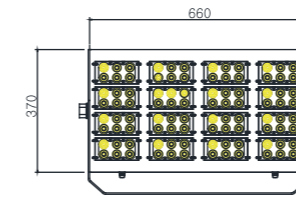

Description

광효율 122lm/w 이상의 고효율 파워 LED 투광등, 스포츠용, 골프장, 고천정등, 항만등, 대형 경기장 등에 설치하며 파워풀하고 역동적인 현장 연출설치 및 유지관리 편리, 대면적 방열구조로 신뢰성 우수

직하조도 / 배광곡선

Test. 100m x 100m x 10m SKL-16TK-2012KS

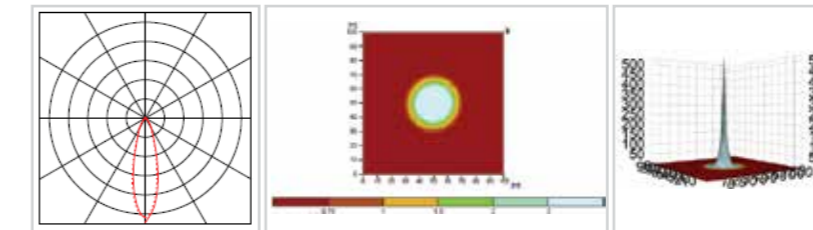

LED 모듈 25W

Specification

모델명 Model name	물품식별번호 G2B	전력 Power consumption	광효율 Luminous efficiency	연색성 CRI	색온도 Color temperature	인증 Certification	금액 Unit price
SKL-16TK-2012KS	23115628	200W	95이상	75이상	5000K		790,000
SKL-16TK-3010KS	23115629	300W	95이상	75이상	5000K		1,180,000
SKL-16TK-4011KS	23115630	400W	95이상	75이상	5000K		1,560,000

LED 투광등 SKL-17TK-1010KS

G2B식별번호 23168518



SKL-17TK-1010KS
LED 100W



SKL-17TK-1210KS
LED 120W



SKL-17TK-1510KS
LED 150W

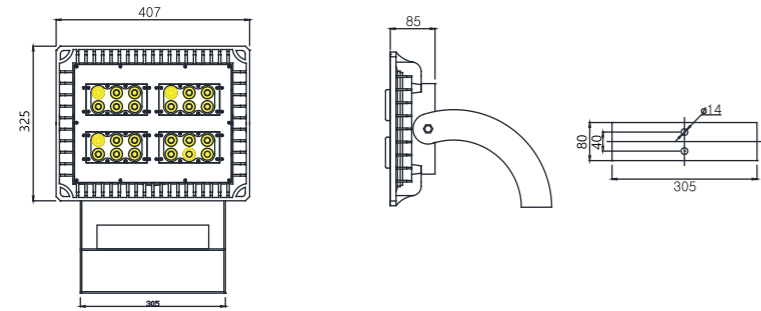

Description

광효율 122lm/w 이상의 원형모듈 15도(30도) 렌즈로 구성되어 조명타워 등에 설치시 광 확산효과가 극대화되며, 스포츠경기장, 항만 등에 배광범위 가장 이상적으로 적용된 고효율제품.

적하조도 / 배광곡선

Test. 100m x 100m x 10m SKL-17TK-1010KS

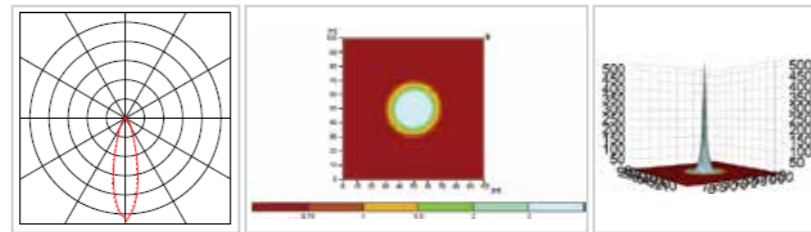

Specification

모델명 Model name	물품식별번호 G2B	전력 Power consumption	광효율 Luminous efficiency	연색성 CRI	색온도 Color temperature	인증 Certification	금액 Unit price
SKL-17TK-1010KS	23168518	100W	95이상	75이상	5000K	☞	490,000
SKL-17TK-1010KG	23300213	100W	132	76	5000K	☞☞☞☞☞☞☞☞☞☞	538,000
SKL-17TK-1210KS	23168519	120W	95이상	75이상	5000K	☞	540,000
SKL-17TK-1510KS	23168520	150W	95이상	75이상	5000K	☞	590,000
SKL-17TK-1510KG	23300210	150W	135	76	5000K	☞☞☞☞☞☞☞☞☞☞	661,000

LED 투광등 SKL-17TK-2010KS

G2B식별번호 23247647



SKL-17TK-2010KS
LED 200W



SKL-17TK-2210KS
LED 220W

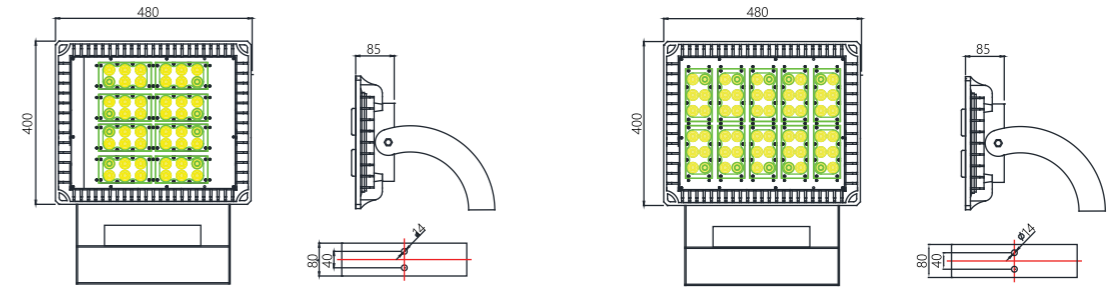

Description

고출력 투광조명기구로서 스포츠경기장, 항만 등에 배광범위 가장 이상적으로 적용.

적하조도 / 배광곡선

Test. 100m x 100m x 10m SKL-17TK-1010KS

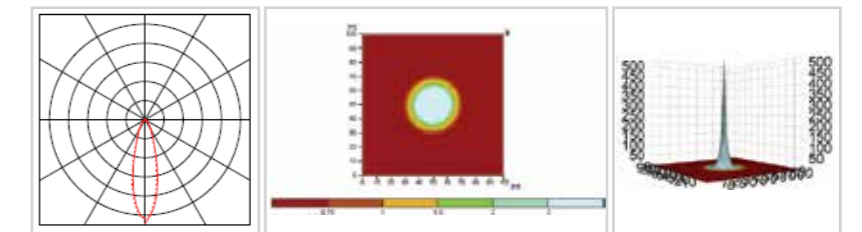

Specification

모델명 Model name	물품식별번호 G2B	전력 Power consumption	광효율 Luminous efficiency	연색성 CRI	색온도 Color temperature	인증 Certification	금액 Unit price
SKL-17TK-2010KS	23247647	200W	95이상	75이상	5000K	☞	642,000
SKL-17TK-2010KG	23300211	200W	134	77	5000K	☞☞☞☞☞☞☞☞☞☞	837,000
SKL-17TK-2210KS	23261283	220W	95이상	75이상	5000K	☞	950,000

LED 터널등 SKL-16TN-1011KG

G2B물품식별번호 23130262



SKL-16TN-1011KG
LED 100W



SKL-16TN-2011KG
LED 200W

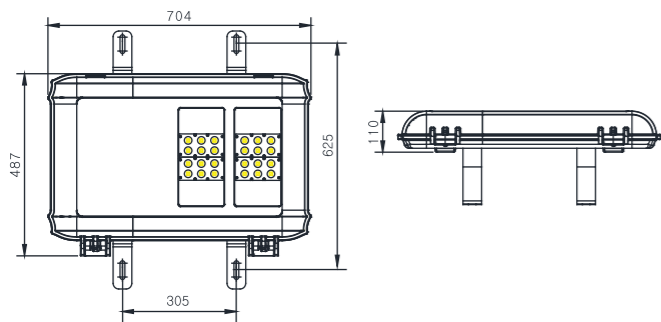

직하조도 / 배광곡선

Test. 10m x 10m x 10m SKL-16TN-1011KG

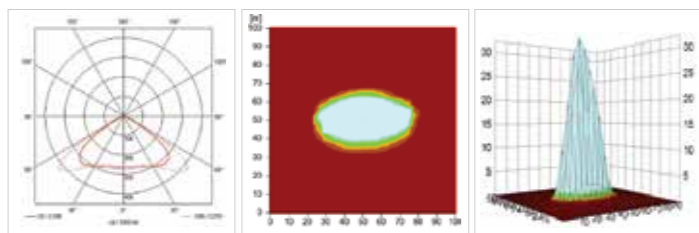

Specification

모델명 Model name	물품식별번호 G2B	전력 Power consumption	광효율 Luminous efficiency	연색성 CRI	색온도 Color temperature	인증 Certification	금액 Unit price
SKL-16TN-1011KG	23130262	100W	133	77	5000K	☞ Ⓢ	470,000
SKL-16TN-2011KG	23130263	200W	129	76	5000K	☞ Ⓢ	660,000

LED 터널등 SKL-18TN-1011KG

G2B물품식별번호



SKL-18TN-1011KG
LED 100W



SKL-18TN-2011KG
LED 200W

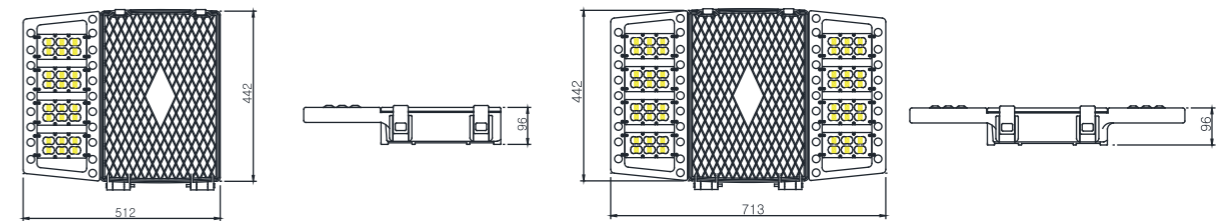

직하조도 / 배광곡선

Test. 10m x 10m x 10m SKL-18TN-1011KG

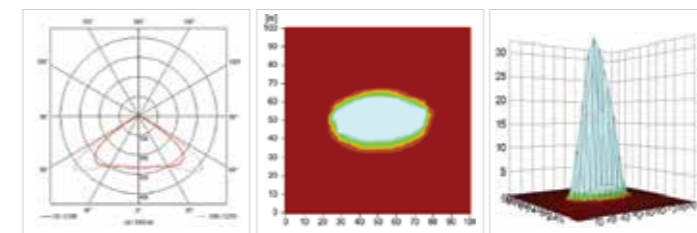

Specification

모델명 Model name	물품식별번호 G2B	전력 Power consumption	광효율 Luminous efficiency	연색성 CRI	색온도 Color temperature	인증 Certification	금액 Unit price
SKL-18TN-1011KG		100W	95이상	75이상	5000K	☞ Ⓢ	
SKL-18TN-2011KG		200W	95이상	75이상	5000K	☞ Ⓢ	

STS 4m 5m 1등용
SKL14-86E-175

G2B물품식별번호 22663567

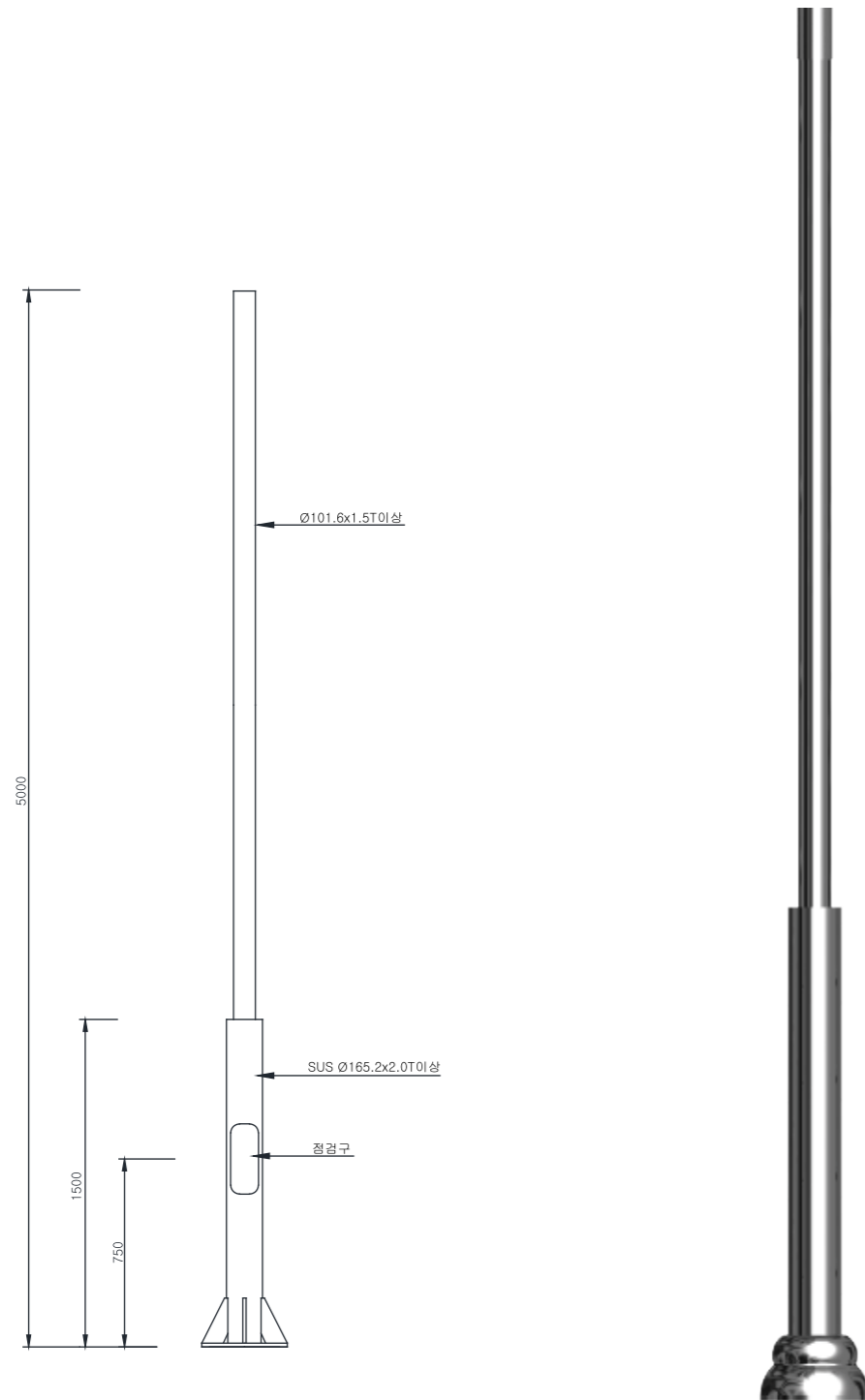

Specification

모델명 Model name	물품식별번호 G2B	규격 Standard	Pole		ARM	양카 anchor	인증 Certification	금액 Unit price
			하단 under	상단 upper				
SKL17-86E-175	23277318	4M*1등용	Ø165.2*2.0T	Ø101.6*2.0T		170*170		510,000
SKL14-86E-175	22663567	5M*1등용	Ø165.2*2.0T	Ø101.6*1.5T		170*170		540,000

STS 4m 5m 6m 9m 10m 12m 1등용
SKL14-45A-175

G2B식별번호 22663541

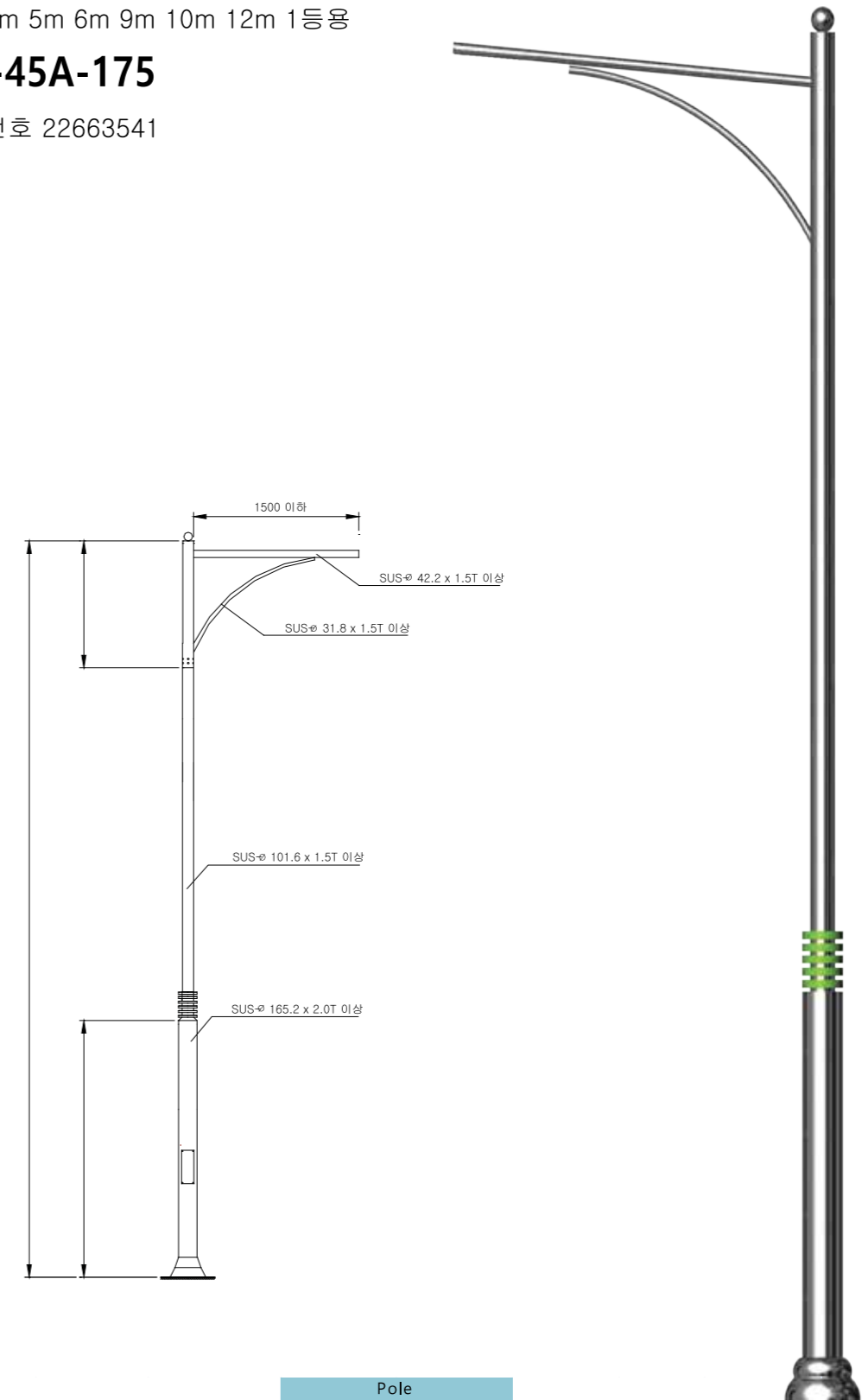

Specification

모델명 Model name	물품식별번호 G2B	규격 Standard	Pole		ARM	양카 anchor	인증 Certification	금액 Unit price
			하단 under	상단 upper				
SKL14-45A-175	22663541	4M*1등용	Ø165.2*2.0T	Ø101.6*1.5T	Ø42.2*1.5T	170*170		630,000
SKL14-55A-175	22663543	5M*1등용	Ø165.2*2.0T	Ø101.6*1.5T	Ø42.2*1.5T	170*170		720,000
SKL14-60A-175	22663544	6M*1등용	Ø165.2*2.0T	Ø101.6*1.5T	Ø42.2*1.5T	170*170		765,000
SKL14-90A-175	22663549	9M*1등용	Ø216.3*2.5T	Ø127*2.5T	Ø60.5*2.0T	230*230		1,610,000
SKL14-100A-175	22663552	10M*1등용	Ø216.3*2.5T	Ø127*2.5T	Ø60.5*2.0T	230*230		1,760,000
SKL14-124A-175	22663559	12M*1등용	Ø216.3*3.0T	Ø127*3.0T	Ø60.5*2.0T	230*230		2,050,000

STS 4m 9m 10m 12m 2등용
SKL14-90A-175D
 G2B식별번호 22663550

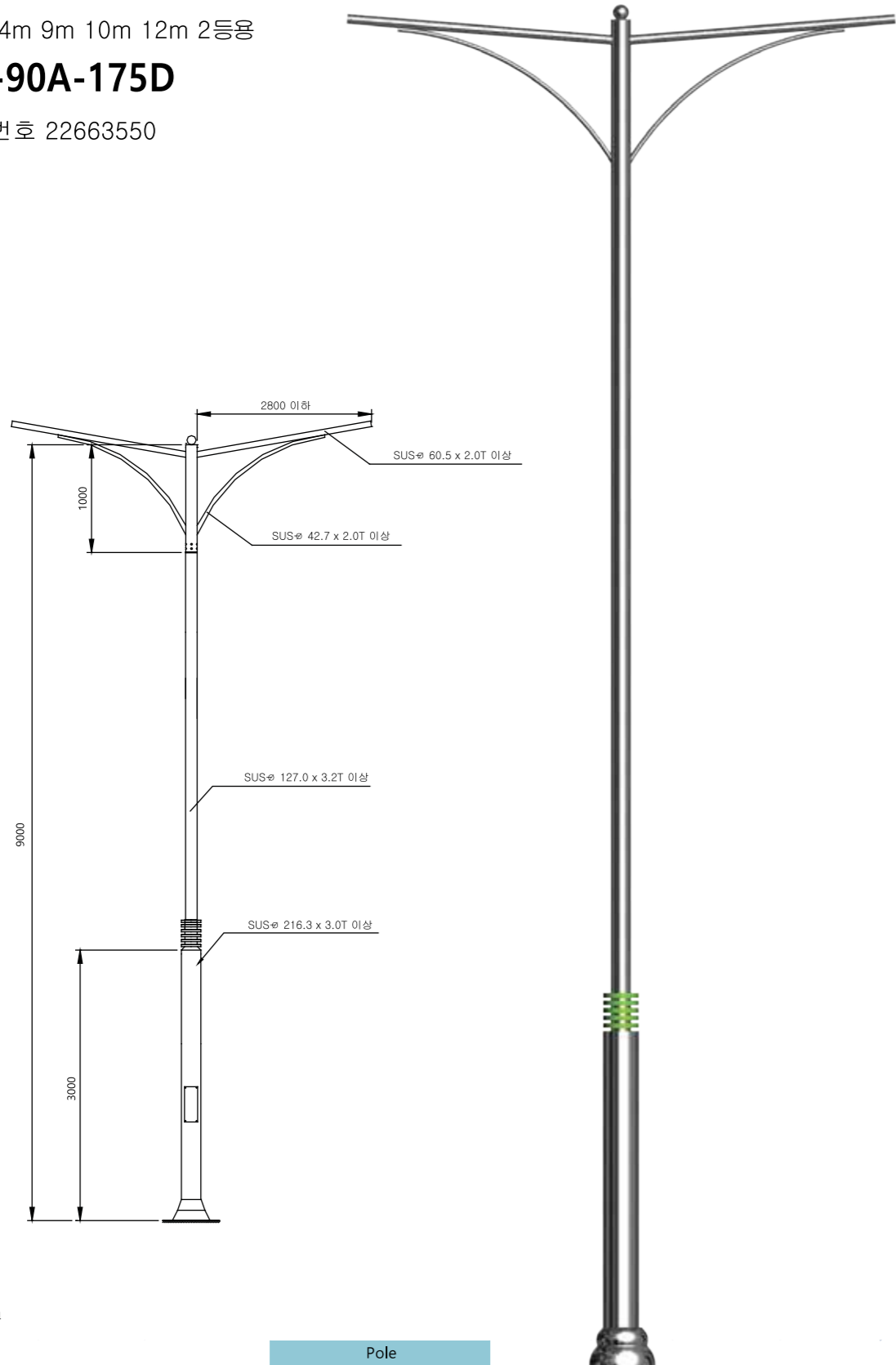

Specification

모델명 Model name	물품식별번호 G2B	규격 Standard	Pole		ARM	양카 anchor	인증 Certification	금액 Unit price
			하단 under	상단 upper				
SKL17-45A-175D	23277321	4M*2등용	Ø165.2*2.0T	Ø101.6*1.5T	Ø42.2*1.5T	170*170		720,000
SKL14-90A-175D	22663550	9M*2등용	Ø216.3*3.0T	Ø127*3.2T	Ø60.5*2.0T	230*230		1,730,000
SKL14-100A-175D	22663553	10M*2등용	Ø216.3*3.0T	Ø127*3.2T	Ø60.5*2.0T	230*230		1,840,000
SKL14-124A-175D	22663560	12M*2등용	Ø216.3*3.0T	Ø127*4.5T	Ø60.5*2.0T	230*230		2,160,000

STS 9m 10m 12m 1등용+보행등
SKL14-90A-175DW
 G2B식별번호 22663551

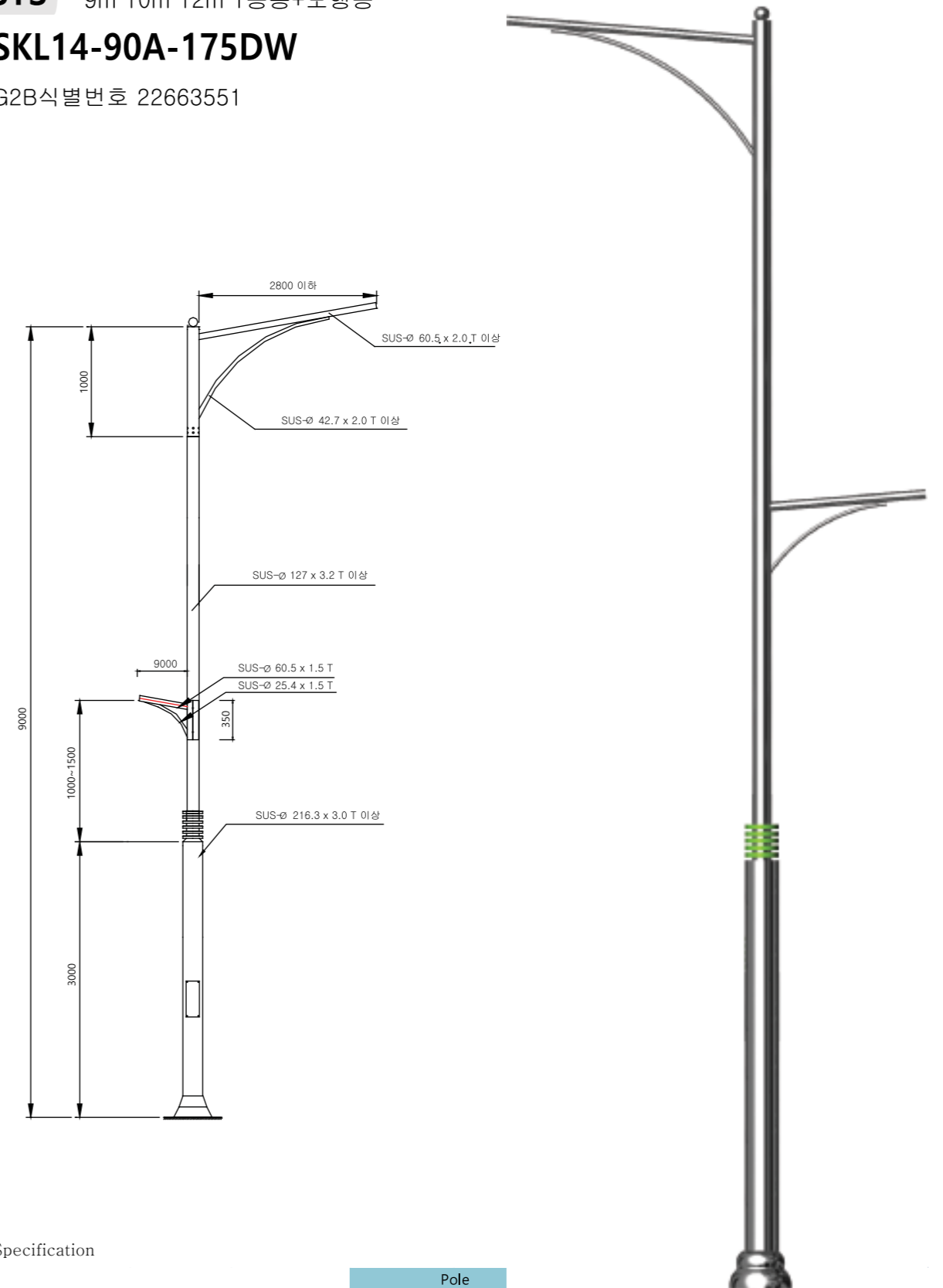

Specification

모델명 Model name	물품식별번호 G2B	규격 Standard	Pole		ARM	양카 anchor	인증 Certification	금액 Unit price
			하단 under	상단 upper				
SKL14-90A-175DW	22663551	9M*1등용+보행	Ø216.3*3.0T	Ø127*3.2T	Ø60.5*2.0T	230*230		1,650,000
SKL14-100A-175DW	22663554	10M*1등용+보행	Ø216.3*3.0T	Ø127*3.2T	Ø60.5*2.0T	230*230		1,800,000
SKL14-124A-175DW	22663561	12M*1등용+보행	Ø216.3*3.0T	Ø127*4.5T	Ø60.5*2.0T	230*230		2,100,000

STS 8m 9m 10m 1등용
SKL17-83A-175

G2B식별번호 23226043

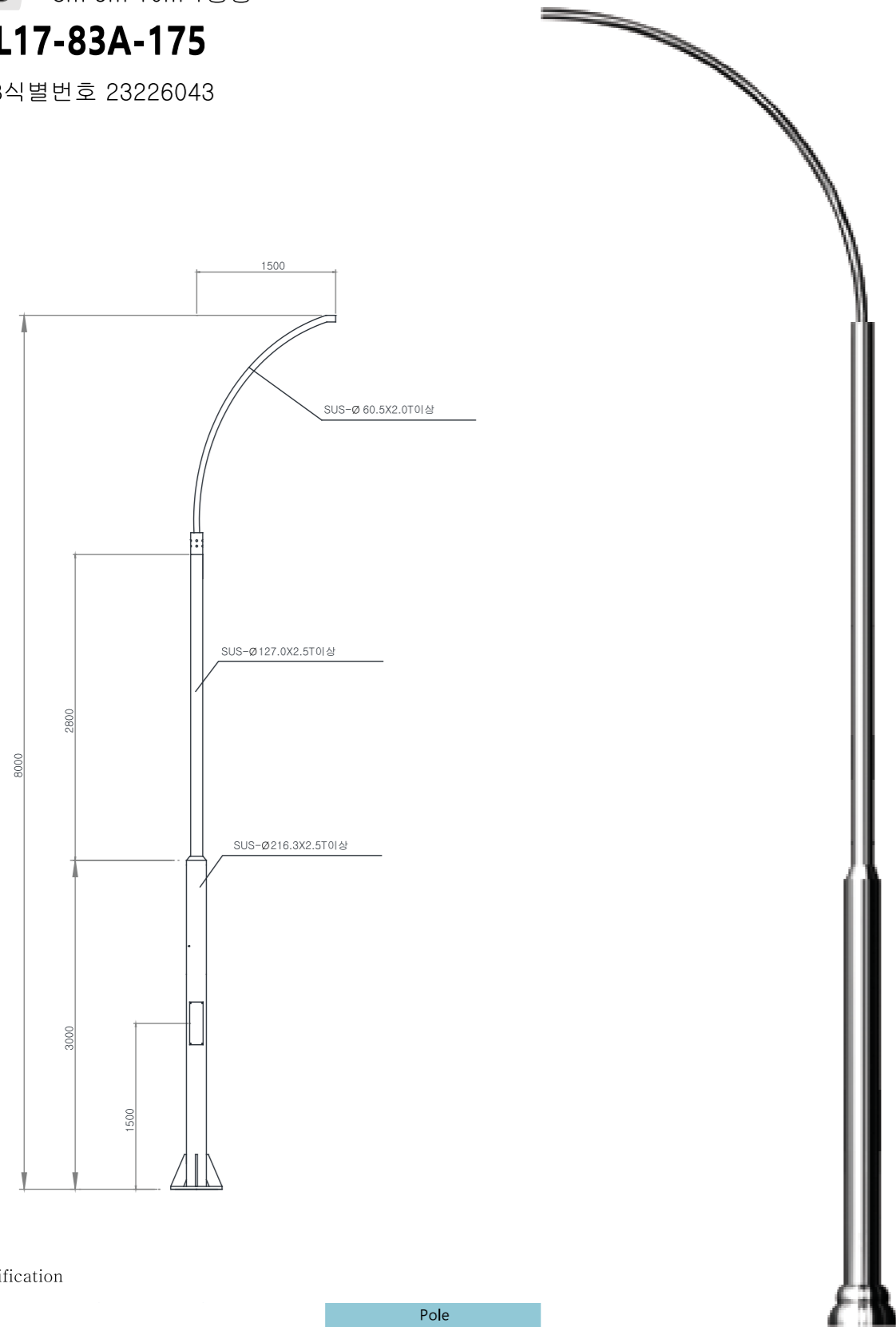

Specification

모 명 Model name	물품식별번호 G2B	규격 Standard	Pole		ARM	양카 anchor	인증 Certification	금액 Unit price
			하단 under	상단 upper				
SKL17-83A-175	23226043	8M*1등용	Ø216.3*2.5T	Ø127*2.5T	Ø60.5*2.0T	230*230		1,500,000
SKL17-93A-175	23226044	9M*1등용	Ø216.3*2.5T	Ø127*2.5T	Ø60.5*2.0T	230*230		1,600,000
SKL17-103A-175	23226045	10M*1등용	Ø216.3*2.5T	Ø127*2.5T	Ø60.5*2.0T	230*230		1,700,000

STS 5m 1등용
SKL14-86A-175

G2B식별번호 22663562

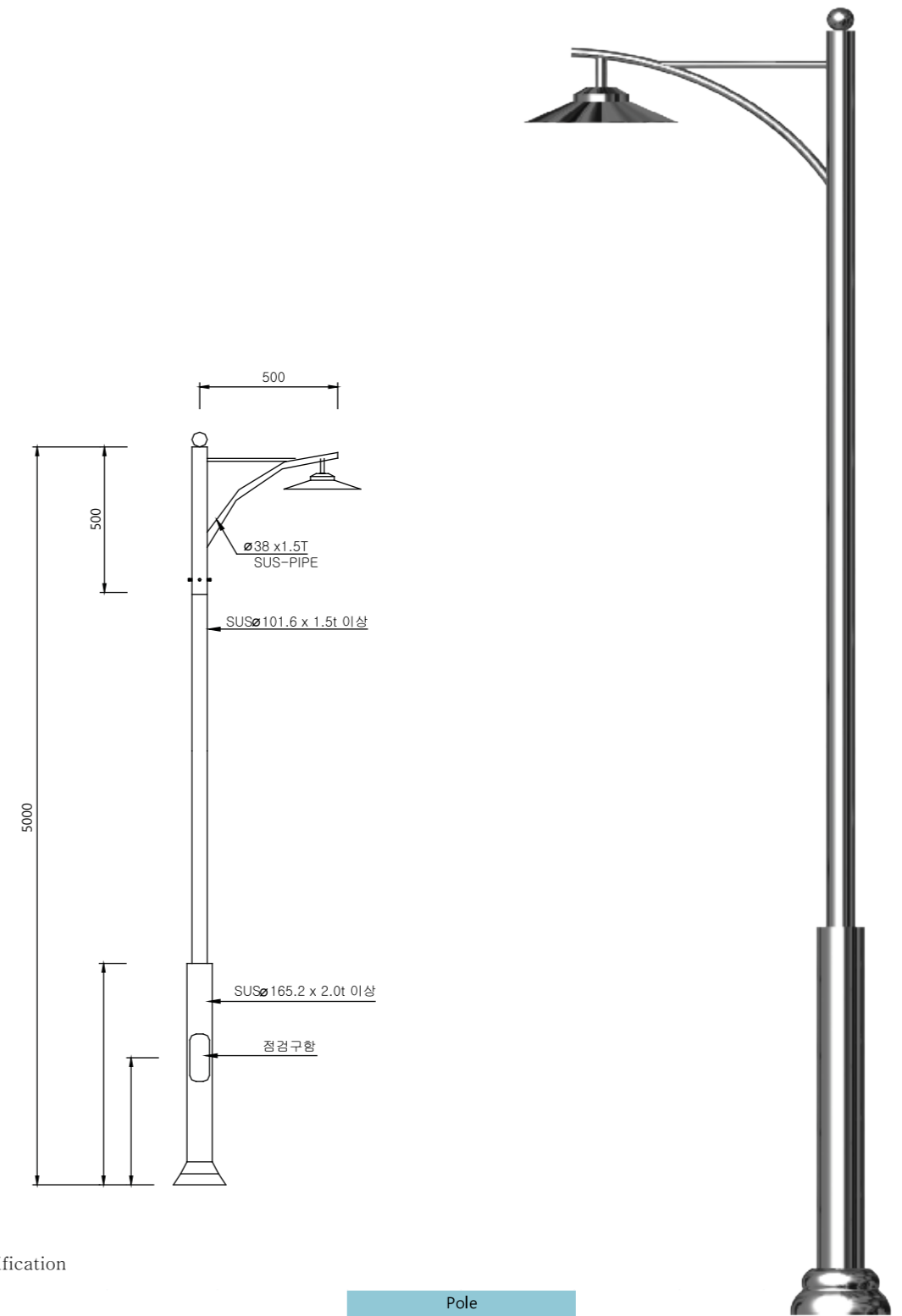

Specification

모델명 Model name	물품식별번호 G2B	규격 Standard	Pole		ARM	양카 anchor	인증 Certification	금액 Unit price
			하단 under	상단 upper				
SKL14-86A-175	22663562	5M*1등용	Ø165.2*2.0T	Ø101.6*1.5T	Ø38*1.5T	170*170		610,000

STS 5m 2등용
SKL14-86A-175D

G2B식별번호 22663563

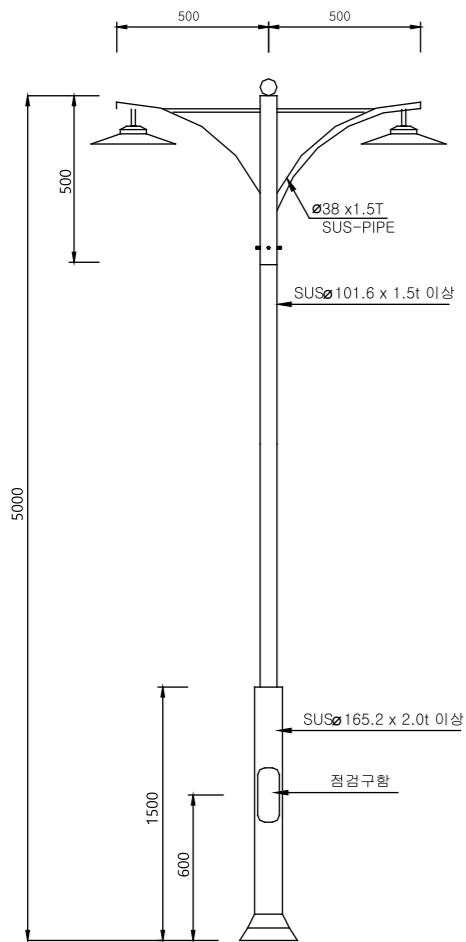

Specification

모델명 Model name	물품식별번호 G2B	Standard	Pole		ARM	양카 anchor	인증 Certification	금액 Unit Price
			하단 under	상단 upper				
SKL14-86A-175D	22663563	5M*2등용	Ø165.2*2.0T	Ø101.6*1.5T	Ø38*1.5T	170*170		630,000

STS 5m 1등용
SKL14-86J-150

G2B식별번호 22663568

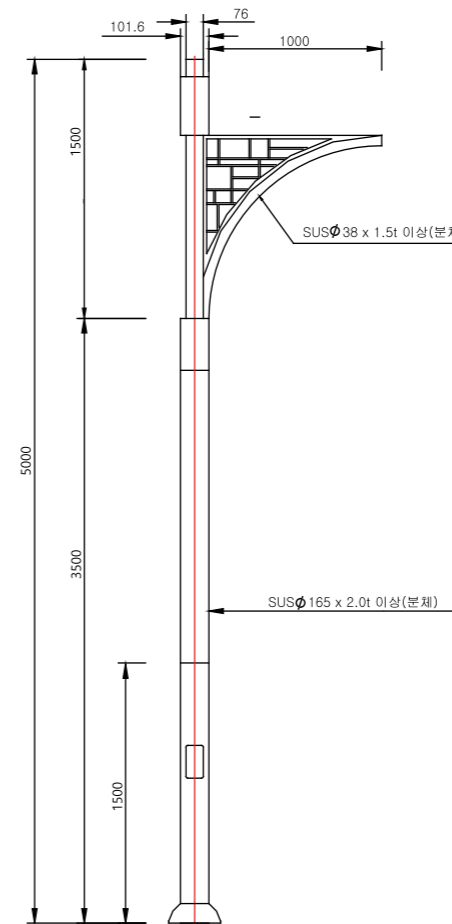

Specification

모델명 Model name	물품식별번호 G2B	규격 Standard	Pole		ARM	양카 anchor	인증 Certification	금액 Unit price
			하단 under	상단 upper				
SKL14-86J-150	22663568	5M*1등용	Ø165.2*2.0T	Ø101.6*1.5T	Ø38*1.5T	170*170		688,000

STEEL 4m 5m 1등용
SKL18-52A-175

G2B물품식별번호 23371277

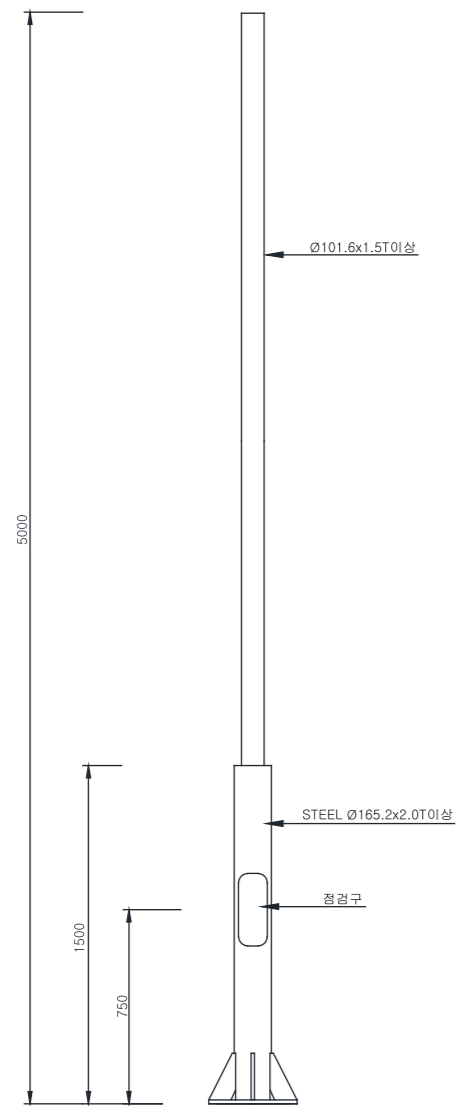

Specification

모델명 Model name	물품식별번호 G2B	규격 Standard	Pole		ARM	앙카 anchor	인증 Certification	금액 Unit price
			하단 under	상단 upper				
SKL18-42A-175	23371278	4M*1등용	Ø165.2*2.0T	Ø101.6*2.0T		170*170		397,000
SKL18-52A-175	23371277	5M*1등용	Ø165.2*2.0T	Ø101.6*1.5T		170*170		510,000

STEEL 4m 5m 6m 8m 9m 10m 12m 1등용
SKL14-42A-150

G2B식별번호 22663500

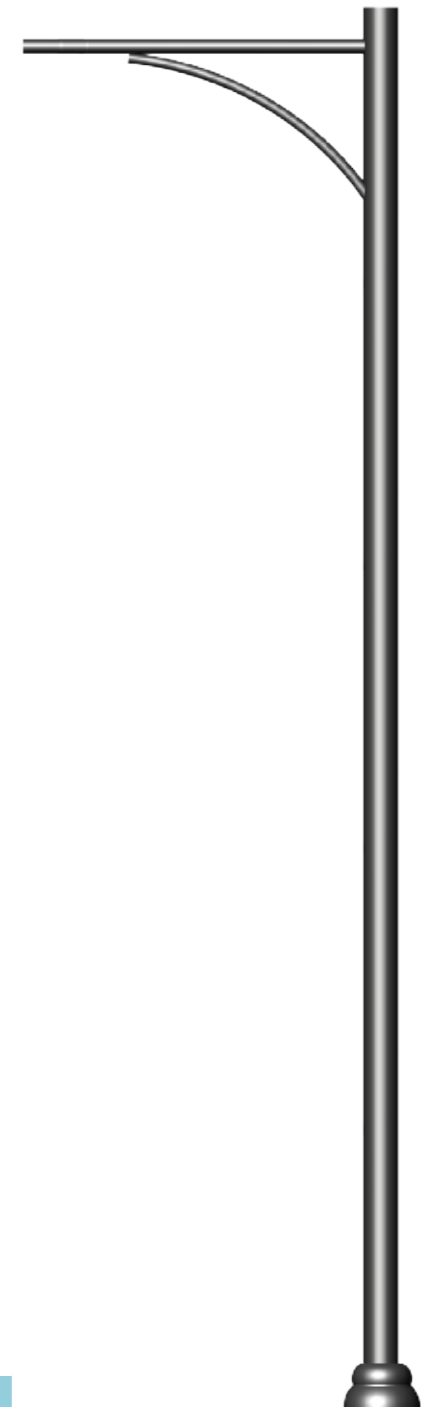
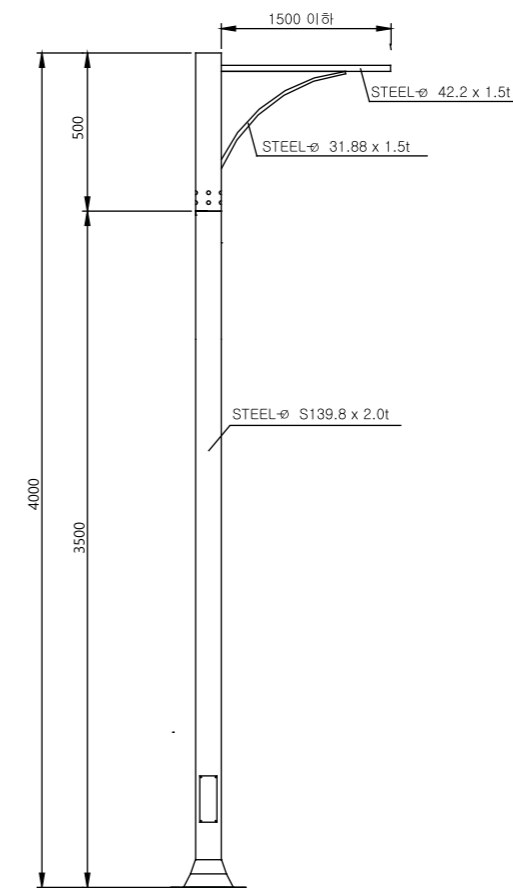

Specification

모델명 Model name	물품식별번호 G2B	규격 Standard	Pole		ARM	앙카 anchor	인증 Certification	금액 Unit price
			하단 under	상단 upper				
SKL14-42A-150	22663500	4M*1등용	Ø139.8*2.0T	Ø42.2*1.5T	Ø42.2*1.5T	170*170		520,000
SKL14-53A-150	22663502	5M*1등용	Ø139.8*2.0T	Ø42.2*1.5T	Ø42.2*1.5T	170*170		600,000
SKL14-62A-175	22663503	6M*1등용	Ø139.8*2.0T	Ø42.2*1.5T	Ø42.2*1.5T	170*170		649,000
SKL17-82A-175	23116924	8M*1등용	Ø165.2*4.0T	Ø60.5*2.0T	Ø60.5*2.0T	230*230		850,000
SKL14-92A-175	22663508	9M*1등용	Ø216.3*4.0T	Ø60.5*2.0T	Ø60.5*2.0T	230*230		1,000,000
SKL17-92A-175	23116925	9M*1등용	Ø165.2*4.0T	Ø60.5*2.0T	Ø60.5*2.0T	230*230		855,000
SKL14-102A-175	22663510	10M*1등용	Ø216.3*4.0T	Ø60.5*2.0T	Ø60.5*2.0T	230*230		1,040,000
SKL17-102A-175	23116927	10M*1등용	Ø165.2*4.0T	Ø60.5*2.0T	Ø60.5*2.0T	230*230		905,000
SKL14-122A-175	22663518	12M*1등용	Ø216.3*4.0T	Ø60.5*2.0T	Ø60.5*2.0T	230*230		1,200,000

STEEL 4m 5m 6m 9m 10m 12m 1등용

SKL14-44A-175

G2B식별번호 22663521

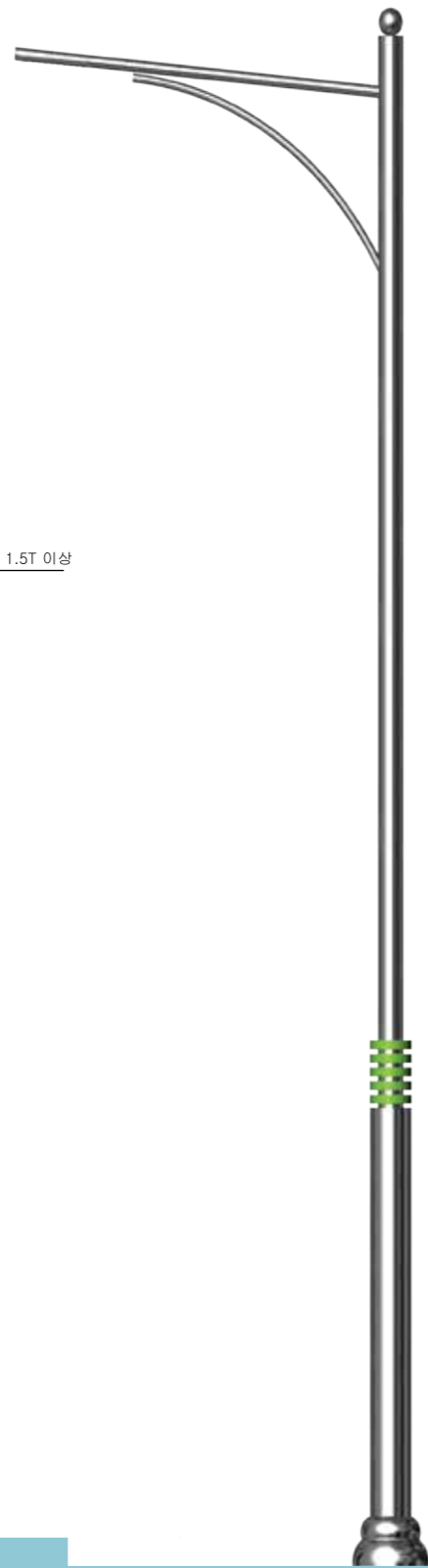
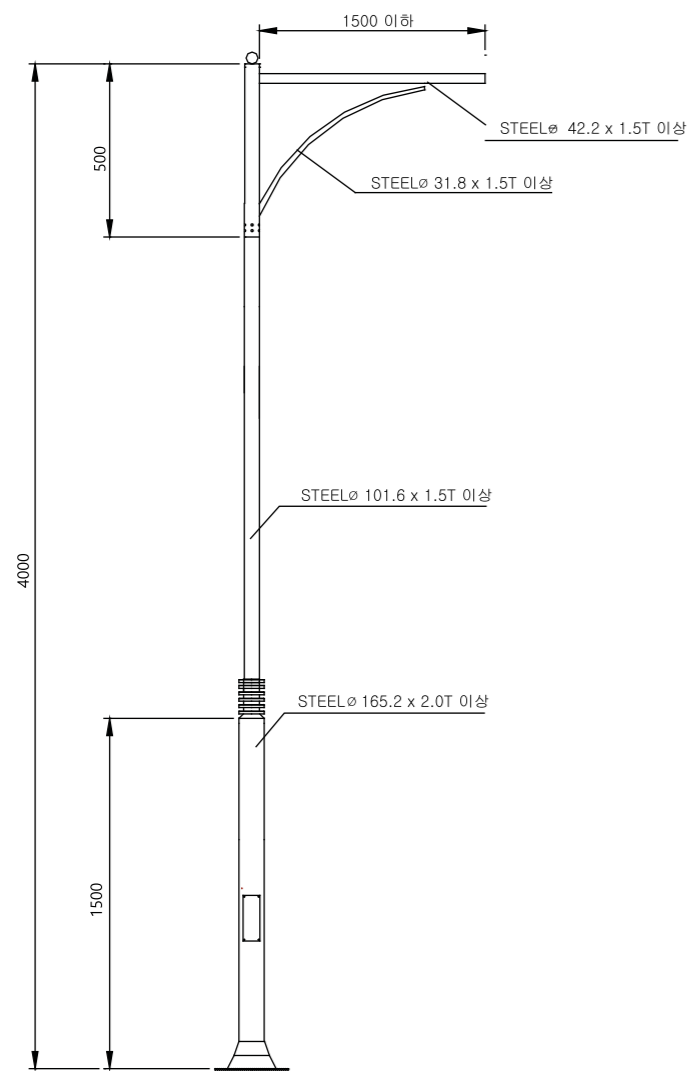

Specification

모델명 Model name	물품식별번호 G2B	규격 Standard	Pole			ARM	양카 anchor	인증 Certification	금액 Unit price
			하단 under	중단 center	상단 upper				
SKL14-44A-175	22663521	4M*1등용	Ø165.2*2.0T		Ø101.6*1.5T	Ø42.2*1.5T	170*170	423,000	
SKL14-54A-175	22663523	5M*1등용	Ø165.2*2.0T		Ø101.6*1.5T	Ø42.2*1.5T	170*170	520,000	
SKL14-64A-175	22663524	6M*1등용	Ø165.2*2.0T		Ø101.6*1.5T	Ø42.2*1.5T	170*170	560,000	
SKL14-94A-175	22663529	9M*1등용	Ø216.3*2.5T		Ø139.8*2.5T	Ø60.5*2.0T	230*230	950,000	
SKL14-104A-175	22663532	10M*1등용	Ø216.3*2.5T		Ø139.8*2.5T	Ø60.5*2.0T	230*230	1,010,000	
SKL14-123A-175	22663538	12M*1등용	Ø216.3*3.0T	Ø165.2*3.0T	Ø114.3*3.0T	Ø60.5*2.0T	230*230	1,100,000	

STEEL 9m 10m 12m 2등용

SKL14-94A-175D

G2B식별번호 22663530

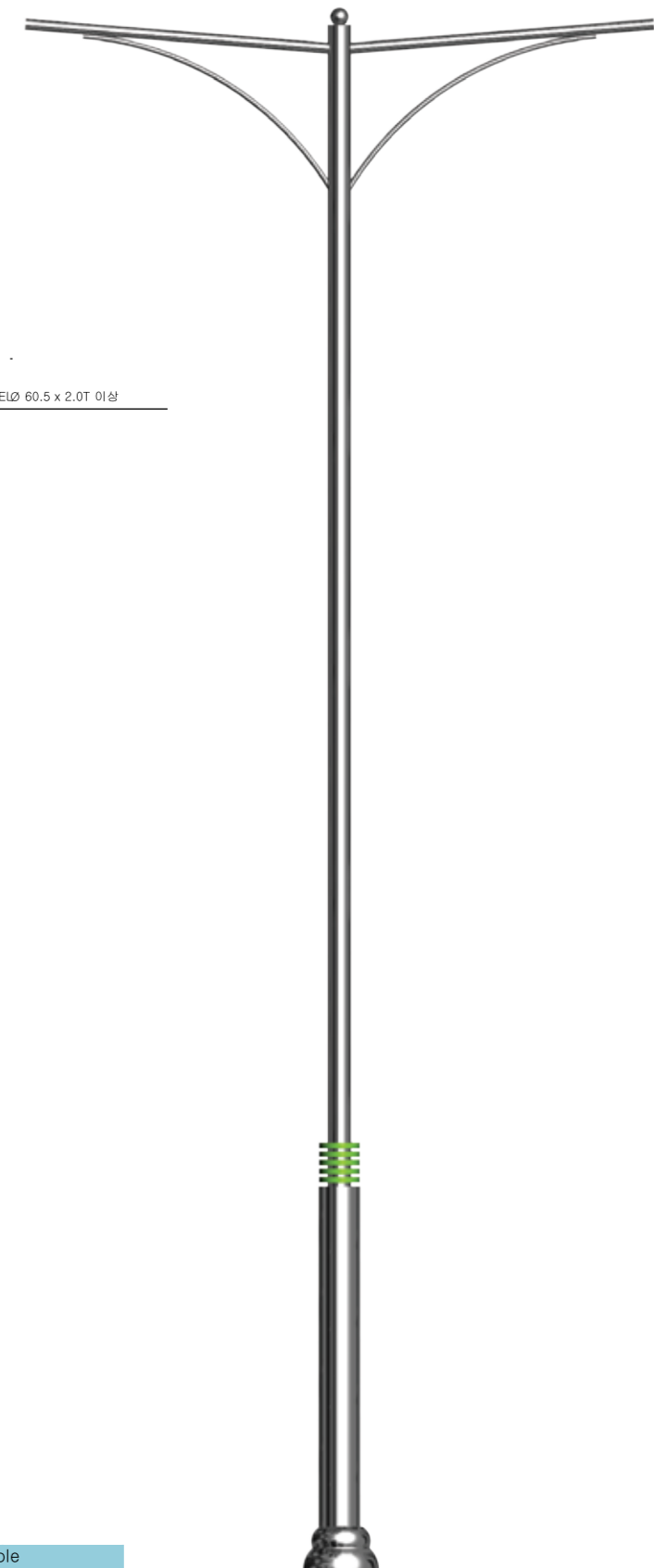
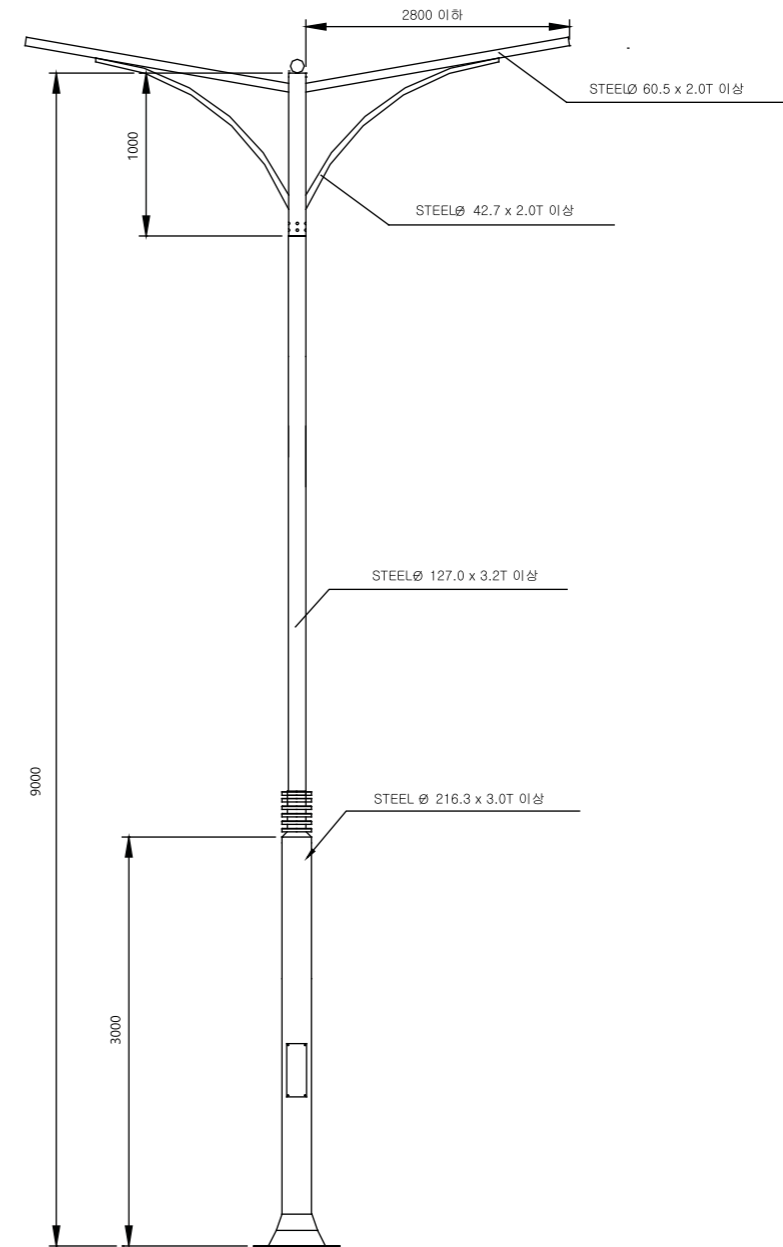

Specification

모델명 Model name	물품식별번호 G2B	규격 Standard	Pole		ARM	양카 anchor	인증 Certification	금액 Unit price
			하단 under	상단 upper				
SKL14-94A-175D	22663530	9M*2등용	Ø216.3*3.0T	Ø139.8*2.9T	Ø60.5*2.0T	230*230	990,000	
SKL14-104A-175D	22663533	10M*2등용	Ø216.3*3.0T	Ø139.8*2.9T	Ø60.5*2.0T	230*230	1,080,000	
SKL14-123A-175D	22663539	12M*2등용	Ø216.3*3.2T	Ø114.3*4.0T	Ø60.5*2.0T	230*230	1,200,000	

STEEL 9m 10m 12m 1등용+보행등
SKL14-94A-175DW

G2B식별번호 22663531

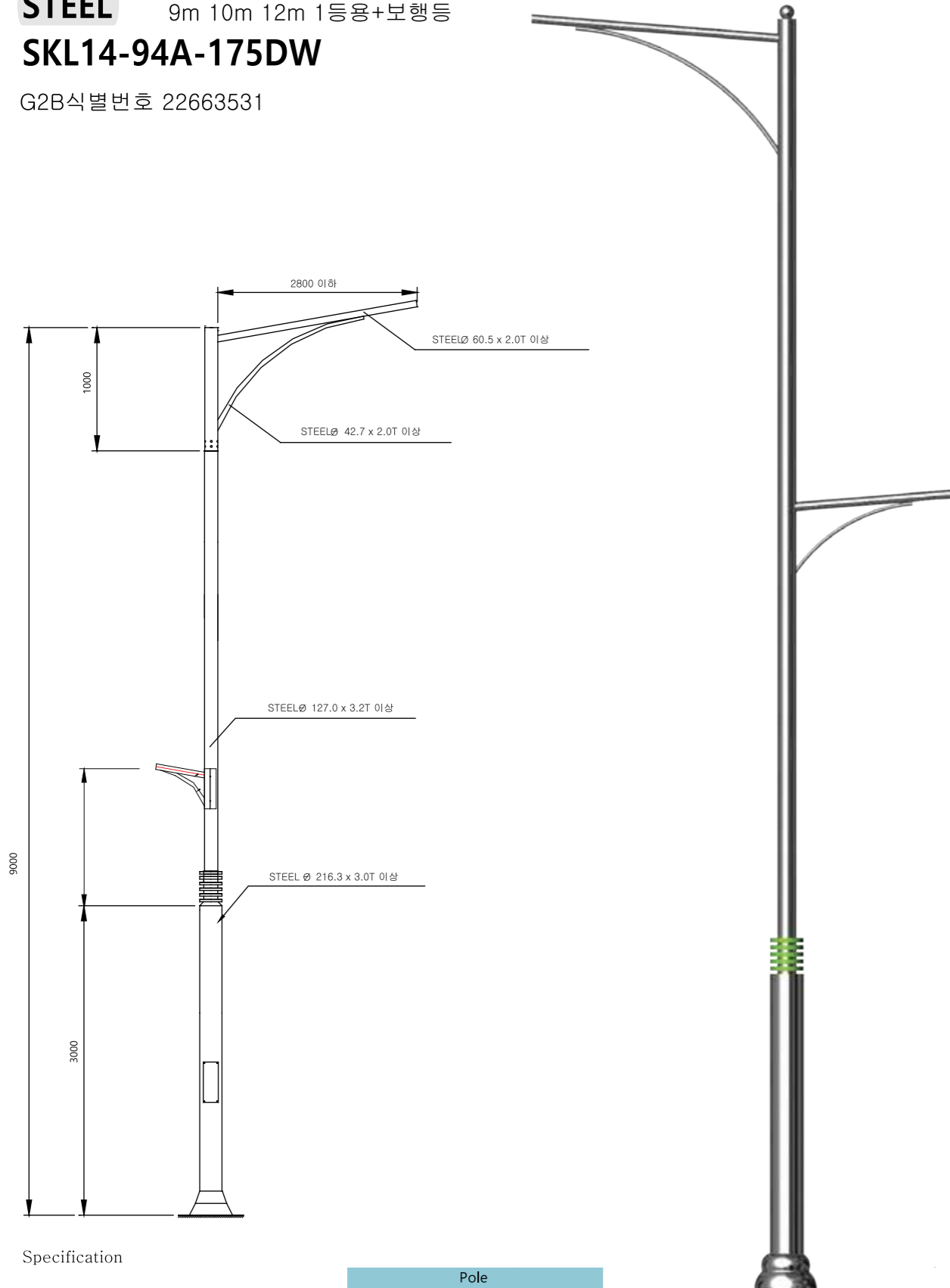

Specification

모델명 Model name	물품식별번호 G2B	규격 Standard	하단 under	중단 center	상단 upper	ARM	양카 anchor	인증 Certification	금액 Unit price
SKL14-94A-175DW	22663531	9M*1등용+보행	Ø216.3*3.0T		Ø139.8*2.9T	Ø60.5*2.0T	230*230	☞	970,000
SKL14-104A-175DW	22663534	10M*1등용+보행	Ø216.3*3.0T		Ø139.8*2.9T	Ø60.5*2.0T	230*230	☞	1,050,000
SKL14-123A-175DW	22663540	12M*1등용+보행	Ø216.3*3.2T	Ø165.2*3.2T	Ø114.3*4.0T	Ø60.5*2.0T	230*230	☞	1,150,000

태양광
SKL-18SUN-5001

G2B물품식별번호 23333872

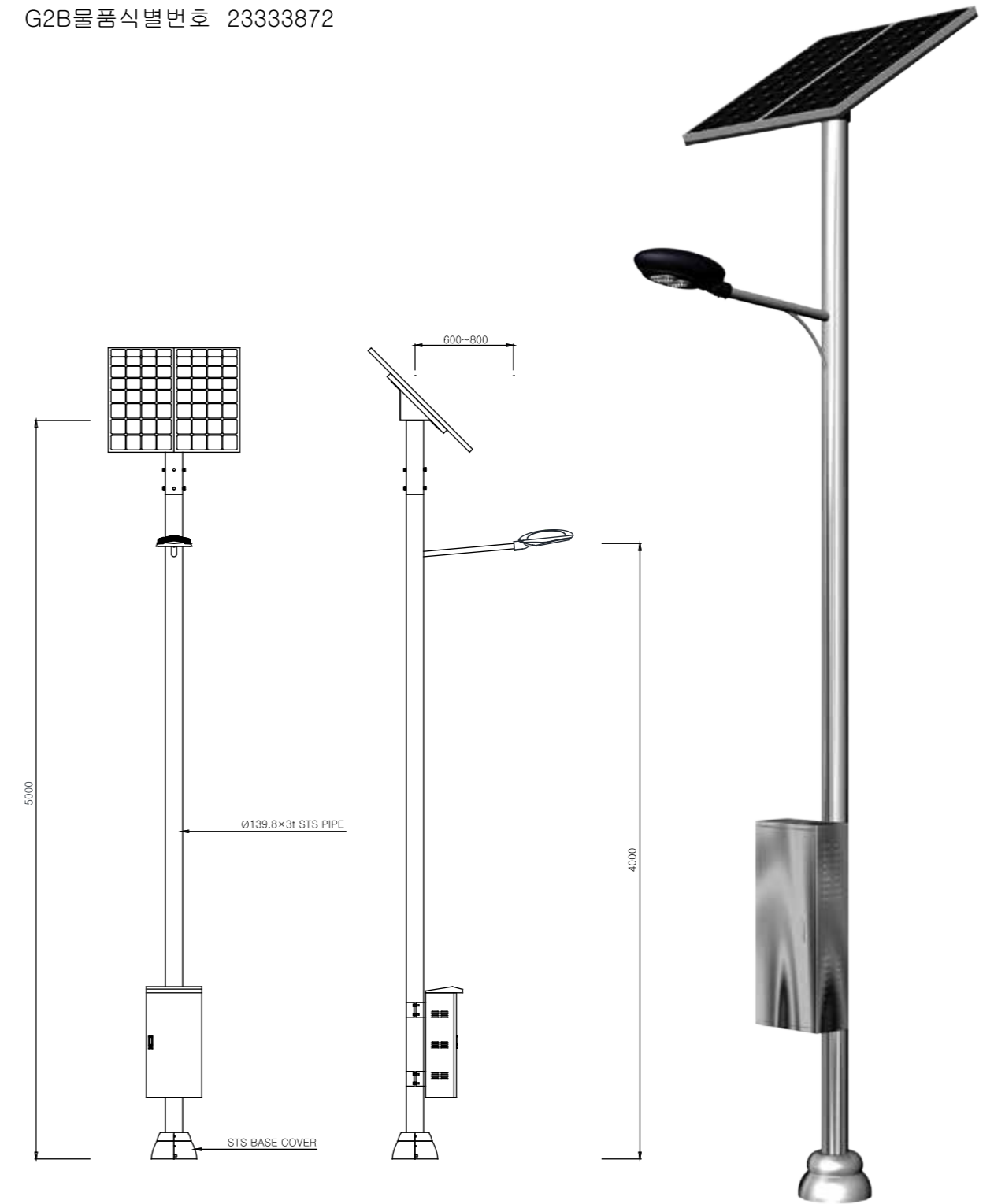

Specification

모델명 Model name	물품식별번호 G2B	규격 Standard	Pole under	태양전지	ARM	양카 anchor	인증 Certification	금액 Unit price
SKL-18SUN-4001	22883375	40W	Ø139.8X3T	100W	Ø42.7X2T	200*200		
SKL-18SUN-5001	23333872	50W	Ø139.8X3T	100W	Ø42.7X2T	200*200		

SKL14-13A-800

G2B물품식별번호 22663569
 가격 : 237,000원

가로등주 부속자재 STS ARM

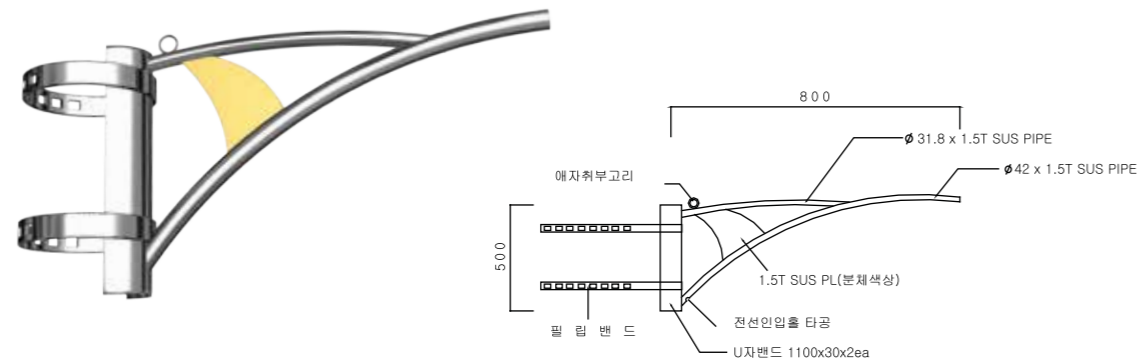

SKL14-13A-800T

G2B물품식별번호 22663570
 가격 : 170,000원

가로등주 부속자재 STEEL ARM

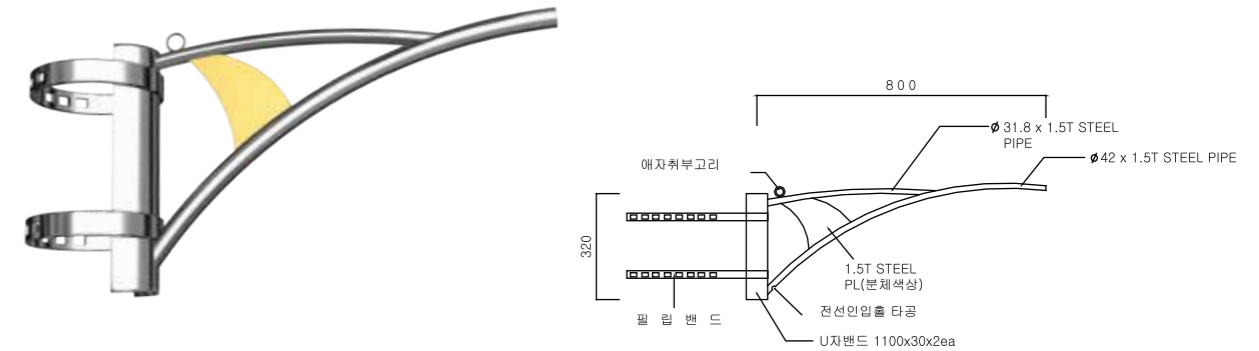

SKL14-13A-500

G2B물품식별번호 22663571
 가격 : 124,000원

SKL14-13A-500T

G2B물품식별번호 22663572
 가격 : 115,000원

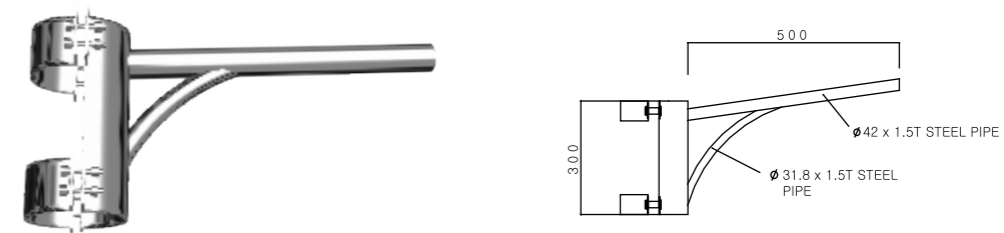

SKL14-13B-22

G2B물품식별번호 22664322
 가격 : 57,000원

배너걸이

SKL14-13BC-139

G2B물품식별번호 22664652

Base Cover

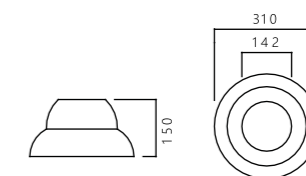
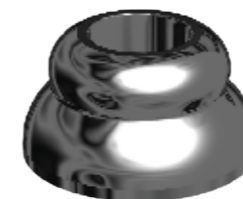

모델명 Model name	물품식별번호 G2B	규격 Standard	재질 Material	인증 Certification	금액 Unit price
SKL14-13BC-139	22664652	Ø310*150	STS		49,000
SKL14-13BC-165	22664653	Ø310*180	STS		57,000
SKL14-13BC-216	22664654	Ø410*220	STS		67,000

LED Downlight

6" 8"



Description

밝고 미려함을 겸비, 고효율, 저비용의 경제성을 갖춰 사무실, 백화점, 유통매장, 극장 등 화사함과 따뜻한 연출이 필요한곳에 주로 사용함.

Dimension

구분 Type	구분 Type	취부방식 Mounted Type	외측 사이즈 SIZE	타공 사이즈 Hole Size
6"		매입	Ø192(W) * 90(H)	Ø150
8"		매입	Ø240(W) * 95(H)	Ø200

Specification_조달우수제품

구분 Type	모델명 Model name	물품식별번호 G2B	전력 Power	광효율 Luminous consumption efficiency	연색성 CRI	색온도 Color temperature	취부방식 Mounted Type	인증 Certification	금액 Unit price
LED다운라이트 6인치	SKL-17DL-1201KG	23218986	12W	116	83	5700K	매입		65,000
	SKL-17DL-1501KG	23218987	15W	115	84	5700K	매입		66,000

Specification_MAS제품

구분 Type	모델명 Model name	물품식별번호 G2B	전력 Power	광효율 Luminous efficiency	연색성 CRI	색온도 Color temperature	취부방식 Mounted Type	인증 Certification	금액 Unit price
LED다운라이트 6인치	SKL-15DL-1202KS	23038686	12W	106	86	5700K	매입		25,500
	SKL-15DL-1502KS	23038687	15W	107	90	5700K	매입		26,000
	SKLED-11DL-1201KS	22249925	12W	90이상	80이상	5700K	매입		45,000
	SKLED-11DL-1501KS	22249926	15W	90이상	80이상	5700K	매입		50,000
LED 다운라이트 (비상용)	SKLED-14DLB-1501KS	22761789	15W	90이상	75이상	5700K	매입		90,000
LED 다운라이트 8인치	SKLED-12DL-2201KS	22424786	22W	90이상	80이상	5700K	매입		65,000
	SKL-15DL-3001KS	22896885	30W	90이상	80이상	5700K	매입		85,000

직하조도 / 배광곡선

Test. 6m x 6m x 3m
SKL-17DL-1501KG

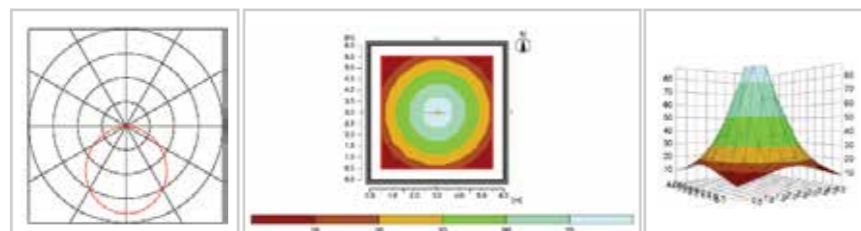

LED Edge Flat Series

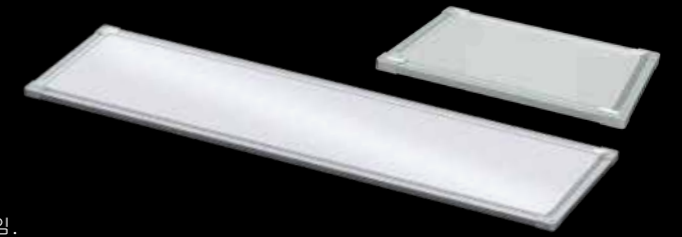

측면발광으로 눈의 피로감이 적게 설계되어 장시간의 정교한 작업을 요하는 사무실 등의 실내조명으로 적합함. 최적발열, 저전력소모, 균일조도 형성 등 실내조명 최적제품임.

Dimension

구분 Type	구분 Type	취부방식 Mounted Type	외측 사이즈 Size	타공 사이즈 Hole Size
LED 엣지 300*600		M-Bar	665(W)*315(D)*18(H)	600(W)*300(D)
LED 엣지 300*1200		M-Bar	1282(W)*315(D)*18(H)	1200(W)*300(D)
LED 엣지 450*450		M-Bar	510(W)*510(D)*18(H)	450(W)*450(D)
LED 엣지 600*600		M-Bar	633(W)*633(D)*18(H)	600(W)*600(D)

Specification_조달우수제품

구분 Type	모델명 Model name	물품식별번호 G2B	전력 Power	광효율 Luminous efficiency	연색성 CRI	색온도 Color temperature	취부방식 Mounted Type	인증 Certification	금액 Unit price
LED 엣지 300*600	SKL-17EG-2501KG	23218983	25W	114	82	5700K	M-Bar		88,000
	SKL-17EG-2501DG	23218982	25W	114	82	5700K	M-Bar		168,000
LED 엣지 300*1200	SKL-16EG-3502DG	23096405	35W	142	83	5700K	M-Bar		144,000
	SKL-16EG-4002DG	23096406	40W	130	86	5700K	M-Bar		129,000
LED 엣지 600*600	SKL-17EG-4005DG	23218948	40W	130	81	5700K	M-Bar		205,000
LED 엣지 600*600	SKL-17EG-4003KG	23218947	40W	130	82	5700K	M-Bar		125,000

Specification_MAS제품

구분 Type	모델명 Model name	물품식별번호 G2B	전력 Power	광효율 Luminous efficiency	연색성 CRI	색온도 Color temperature	취부방식 Mounted Type	인증 Certification	금액 Unit price
LED 엣지 300*600	SKL-15EG-2501KS	22898928	25W	103	86	5700K	M-Bar		80,000
	SKL-15EG-2501DG	22920074	25W	90.5	87	5700K	M-Bar		138,000
LED 엣지 300*1200	SKL-16EG-2801KS	23127444	28W	142	82	5700K	M-Bar		110,000
	SKL-15EG-3501KS	22854045	35W	140	83	5700K	M-Bar		110,000
	SKL-15EG-3501DG	22920075	35W	118	89	5700K	M-Bar		170,000
	SKL-15EG-4001KS	22844695	40W	125	86	5700K	M-Bar		82,000
LED 엣지 450*450	SKL-15EG-5001KS	22844696	50W	95이상	80이상	5700K	M-Bar		90,000
	SKL-15EG-3507KS	22917565	35W	117	87	5700K	M-Bar		100,000
LED 엣지 600*600	SKL-15EG-3507DG	22920084	35W	111	87	5700K	M-Bar		169,200
	SKL-15EG-3502KS	22898929	35W	120	86	5700K	M-Bar		110,000

LED Flat Series

안정된 휘도값으로 밝은 조도를 확보하며 광 확산성이 좋아 빛이 골고루 퍼져
충분한 밝기와 연색성을 요구하는 환경에 적합함.
학교, 사무실, 병원 등 정교하고 안정된 작업을 요하는 곳에 적합함.

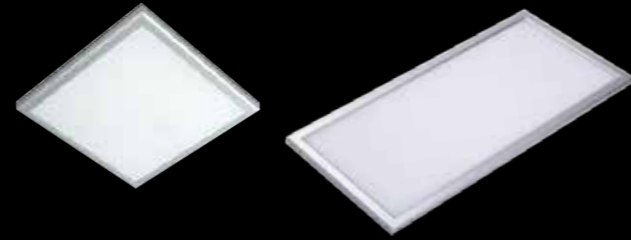

Dimension

구분 Type	취부방식 Mounted Type	외측 사이즈 Size	타공 사이즈 Hole Size
	M-Bar	665(W)*315(D)*42(H)	600(W)*300(D)
	직부	660(W)*320(D)*60(H)	-
	M-Bar	1294(W)*315(D)*42(H)	1200(W)*300(D)
	직부	1200(W)*320(D)*60(H)	-
	M-Bar	315(W)*315(D)*42(H)	300(W)*300(D)
	Clip-Bar	300(W)*300(D)*42(H)	300(W)*300(D)
	M-Bar	510(W)*510(D)*42(H)	450(W)*450(D)
	직부	460(W)*460(D)*60(H)	-
	M-Bar	660(W)*660(D)*42(H)	600(W)*600(D)
	T-Bar	600(W)*600(D)*42(H)	600(W)*600(D)
	Clip-Bar	600(W)*600(D)*42(H)	600(W)*600(D)

Specification_조달우수제품

구분 Type	모델명 Model name	물품식별번호 G2B	전력 Power consumption	광효율 Luminous efficiency	연색성 CRI	색온도 Color temperature	취부방식 Mounted Type	인증 Certification	금액 Unit price
LED 평판조명등 300*600	SKL-18MB-2505DG	23390001	25W	109	85	5700K	M-Bar		166,000
LED 평판조명등 300*1200	SKL-18MB-4010KG	23393658	40W	116	86	5700K	M-Bar		133,000
	SKL-18MB-4011DG	23393657	40W	116	85	5700K	M-Bar		212,000
LED 평판조명등 600*600	SKL-18MB-4013KG	23390000	40W	122	85	5700K	M-Bar		138,000

Specification_MAS제품

구분 Type	모델명 Model name	물품식별번호 G2B	전력 Power consumption	광효율 Luminous efficiency	연색성 CRI	색온도 Color temperature	취부방식 Mounted Type	인증 Certification	금액 Unit price
LED 평판조명등 300*600(비상용)	SKLED-14MBB-2501KS	22653313	25W	90이상	80이상	5700K	M-Bar		168,000
	SKL-16MB-4005KS	23041523	40W	128	87	5700K	M-Bar		98,000
	SKLED-11MB-4001KS	22253304	40W	95이상	80이상	5700K	M-Bar		123,000
	SKLED-12MB-4003KS	22547613	40W	95이상	80이상	5700K	M-Bar		127,000
LED 평판조명등 300*1200	SKLED-17MB-4001KS	23267975	40W	95이상	80이상	5700K	M-Bar		178,000
	SKLED-14MB-5007KS	22730946	50W	95이상	80이상	5700K	M-Bar		117,000
	SKL-13MB-5006KG	23218964	50W	100	81	5700K	M-Bar		120,000
	SKLED-12GR-5002KG	22409436	50W	95이상	80이상	5700K	M-Bar		123,500
	SKLED-11MB-5001KS	22253305	50W	95이상	80이상	5700K	M-Bar		160,000
SKLED-11GB-5001KS	22249934	50W	95이상	80이상	5700K	직부		195,000	
LED 평판조명등 300*1200(비상용)	SKLED-14MBB-5001KS	22751180	50W	95이상	80이상	5700K	M-Bar		210,000
LED 평판조명등 300*300	SKLED-12MB-1501KS	22427734	15W	90이상	80이상	5700K	M-Bar		75,000
	SKLED-12DP-1504KS	22547612	15W	90이상	80이상	5700K	Clip-Bar		90,000
LED 평판조명등 450*450	SKLED-11GB-4501KS	22249932	45W	95이상	80이상	5700K	직부		180,000
LED 평판조명등 600*600	SKL-12MB-5004KG	23218962	50W	115	84	5700K	M-Bar		120,000
	SKLED-12MB-5004KS	22547887	50W	95이상	80이상	5700K	M-Bar		133,000
	SKLED-12DP-5004KS	22547883	50W	95이상	80이상	5700K	Clip-Bar		134,000
	SKL-17MB-5001KS	23267974	50W	95이상	80이상	5700K	Clip-Bar		178,000
	SKLED-11MB-6001KS	22253302	60W	95이상	80이상	5700K	M-Bar		197,000
	SKLED-11TB-6001KS	22249927	60W	95이상	80이상	5700K	T-Bar		197,000
SKLED-11DP-6001KS	22249928	60W	95이상	80이상	5700K	Clip-Bar		197,000	

직하조도 / 배광곡선

Test. 6m x 6m x 3m
SKL-18MB-2505DG

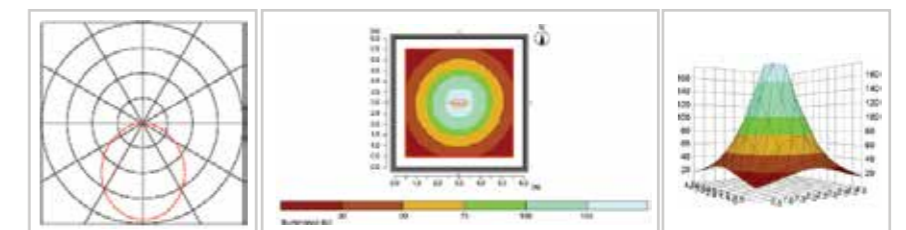

LED 회전철판등

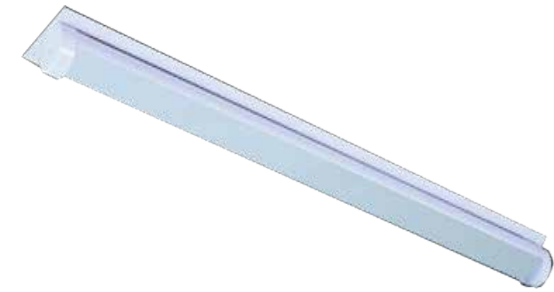

Description

눈부심 방지 광학설계로 시력보호 탁월 및 회전기능으로 선택부분 정교한 조사 기능을 가진 직부형 LED등기구

Dimension

구분 Type	취부방식 Mounted Type	외측 사이즈 Size	타공 사이즈 Hole Size
	직부	1250(W)*160(D)*96(H)	-

Specification_조달우수제품

구분 Type	모델명 Model name	물품식별번호 G2B	전력 Power consumption	광효율 Luminous efficiency	연색성 CRI	색온도 Color temperature	취부방식 Mounted Type	인증 Certification	금액 Unit price
LED 철판등	SKL-17SP-1801KG	23218980	18W	99	83	5700K	직부		102,000
	SKL-17SP-2501KG	23218981	25W	100	83	5700K	직부		102,000

Specification_MAS제품

구분 Type	모델명 Model name	물품식별번호 G2B	전력 Power consumption	광효율 Luminous efficiency	연색성 CRI	색온도 Color temperature	취부방식 Mounted Type	인증 Certification	금액 Unit price
LED 철판등	SKL-12SP-1801KG	23219005	18W	94	80.2	5700K	직부		84,600
	SKL-11SP-2501KG	23219002	25W	90	84	5700K	직부		84,600
	SKLED-11SP-2501KS	22263208	25W	90이상	80이상	5700K	직부		84,600

직하조도 / 배광곡선
Test. 6m x 6m x 3m
SKL-17SP-2501KG

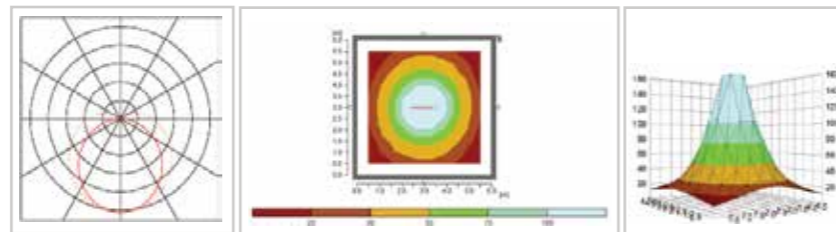

LED 갓등 RACEWAY(주차장등)



Description

깔끔하고 미려한 디자인, 고효율 제품.
안정된 휘도값으로 밝은 조도를 확보하며 광 확산성이 좋아 빛이 골고루 퍼져 충분한 밝기와 연색성을 요구하는 환경에 적합함.
Raceway일반형, 펜던트형 타입이 있음.

Dimension

구분 Type	취부방식 Mounted Type	외측 사이즈 Size	타공 사이즈 Hole Size
	직부	1255(W)*87(D)*65(H)	-
	직부	1255(W)*87(D)*65(H)	-
	직부	1185(W)*95(D)*50(H)	-

Specification_조달우수제품

구분 Type	모델명 Model name	물품식별번호 G2B	전력 Power consumption	광효율 Luminous efficiency	연색성 CRI	색온도 Color temperature	취부방식 Mounted Type	인증 Certification	금액 Unit price
LED 갓등	SKL-17RY-4001KG	23218949	40W	106	88	5700K	직부		107,000

Specification_MAS제품

구분 Type	모델명 Model name	물품식별번호 G2B	전력 Power consumption	광효율 Luminous efficiency	연색성 CRI	색온도 Color temperature	취부방식 Mounted Type	인증 Certification	금액 Unit price
LED 갓등	SKLED-11RY-4001KS	22253307	40W	95이상	80이상	5700K	직부		103,000
	SKLED-11RY-4001PP	22249929	40W	95이상	80이상	5700K	펜던트		105,000
	SKLED-14RY-1800KS	22754442	18W	136	85	5700K	직부		54,000
	SKLED-14RY-2500KS	22754443	25W	128	85	5700K	직부		65,000
LED 갓등 (비상등)	SKLED-14RB-4001KS	22653314	40W	95이상	75이상	5700K	직부		229,000

직하조도 / 배광곡선
Test. 6m x 6m x 3m
SKL-17RY-4001KG

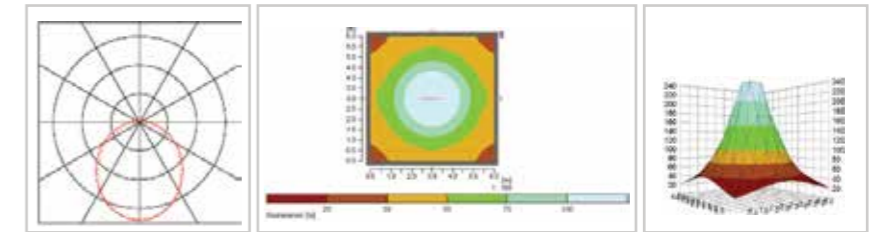

LED 방습등



Description

지하철 및 지상철 플랫폼, 주차장, 터널, 식품업체, 냉동고, 주방 등 먼지 및 습기가 많은 곳에 사용되는 LED방진방습등

Dimension

구분 Type	취부방식 Mounted Type	외측 사이즈 Size	타공 사이즈 Hole Size
	직부	1260(W)*130(D)*105(H)	-

Specification

구분 Type	모델명 Model name	물품식별번호 G2B	전력 Power consumption	광효율 Luminous efficiency	연색성 CRI	색온도 Color temperature	취부방식 Mounted Type	인증 Certification	금액 Unit price
LED 방습등	SKLED-11SS-4001KS	22249931	40W	95이상	80이상	5700K	직부	☉	165,000

직하조도 / 배광곡선
Test. 6m x 6m x 3m
SKLED-11SS-4001KS

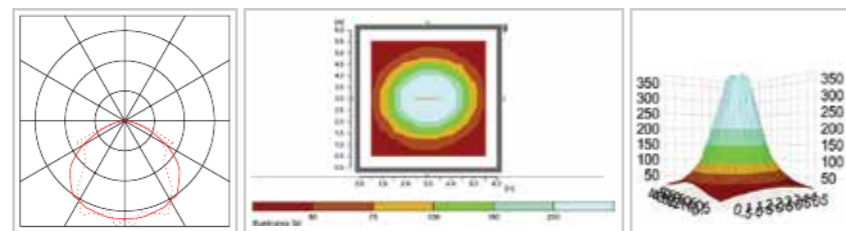

LED 직부등



Description

광도가 높고 균일한 빛을 제공하며 눈부심 방지 광학설계로 시력보호 탁월함.

Dimension

구분 Type	취부방식 Mounted Type	외측 사이즈 Size	타공 사이즈 Hole Size
	직부	1285(W)*200(D)*50(H)	-
	직부	600(W)*200(D)*50(H)	-

Specification

구분 Type	모델명 Model name	물품식별번호 G2B	전력 Power consumption	광효율 Luminous efficiency	연색성 CRI	색온도 Color temperature	취부방식 Mounted Type	인증 Certification	금액 Unit price
LED 직부	SKLED-11GB-4001KS	22263209	40W	95이상	80이상	5700K	직부	☉	175,000
			25W	95이상	80이상	5700K	직부	☉	
LED 직부(비상등)	SKLED-14AGB-4001KS	22653312	40W	95이상	75이상	5700K	직부	☉	239,000

직하조도 / 배광곡선
Test. 6m x 6m x 3m
SKLED-11GB-4001KS

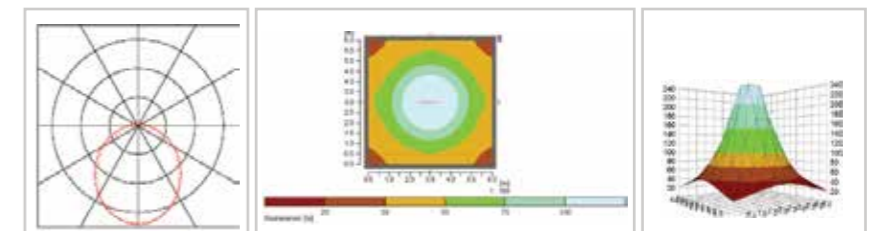

LED CMB등

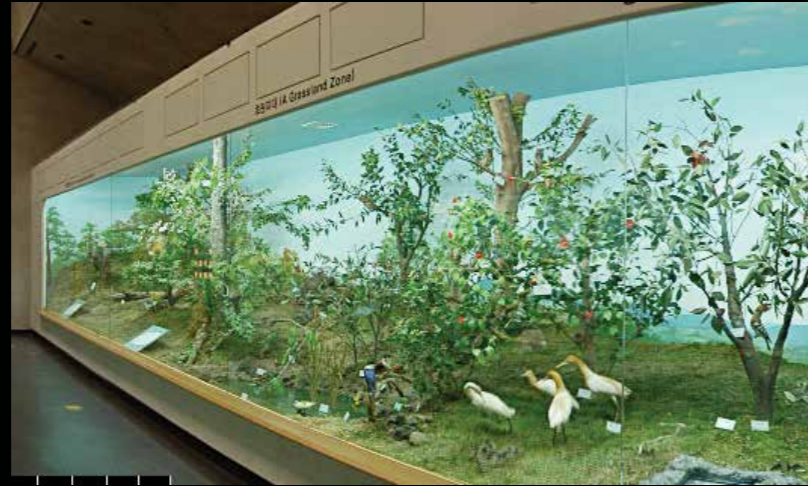

Description

안전, 보안이 강화된 장소에 사용하기 적합한 구조로 설계되어 조립, 설치, 해체 등은 설계되어진 일방향에서만 가능토록 함.

Dimension

구분 Type	취부방식 Mounted Type	외측 사이즈 Size	타공 사이즈 Hole Size
	직부	620(W)*142(D)*37(H)	-

Specification

구분 Type	모델명 Model name	물품식별번호 G2B	전력 Power consumptior	광효율 Luminous efficiency	연색성 CRI	색온도 Color temperature	취부방식 Mounted Type	인증 Certification	금액 Unit price
LED CMB등	SKL-15CMB-2001KS	22811981	20W	90이상	80이상	5700K	직부	☞	100,000
	SKL-15CMB-3001KS	22811982	30W	90이상	80이상	5700K	직부	☞	105,000
	SKL-15CMB-4001KS	22811983	40W	95이상	80이상	5700K	직부	☞	110,000

직하조도 / 배광곡선

Test. 6m x 6m x 3m
SKL-15CMB-2001KS

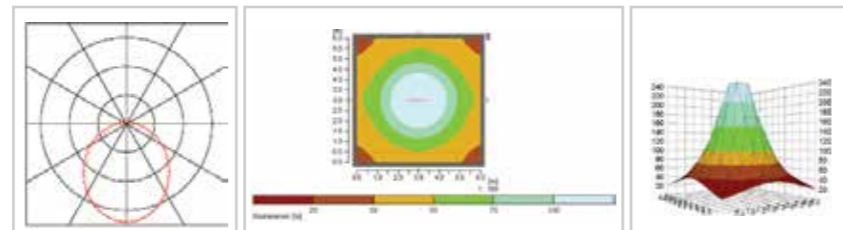

LED 원형직부등



Description

광도가 높고 균일한 빛을 제공하며 눈부심이 없음. 낮은 온도에서도 변함없는 밝기 유지 및 내구성 강함. 분진이 들어갈 수 없는 구조 방진등기구.

Dimension

구분 Type	취부방식 Mounted Type	외측 사이즈 Size	타공 사이즈 Hole Size
	직부	Ø 270(W)*60(H)	-

Specification

구분 Type	모델명 Model name	물품식별번호 G2B	전력 Power consumptior	광효율 Luminous efficiency	연색성 CRI	색온도 Color temperature	취부방식 Mounted Type	인증 Certification	금액 Unit price
LED 원형직부	SKL-15GB-1501KS	22844698	15W	90이상	80이상	5700K	직부	☞	50,000

직하조도 / 배광곡선

Test. 6m x 6m x 3m
SKL-15GB-1501KS

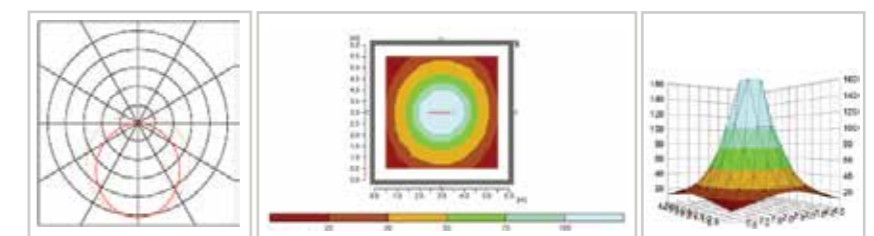

LED 벽부등 SKL-17GB-1050KS

LED 센서등



Description

일반벽부형 글로브 안의 램프끼움구조가 아닌
글로브 일체형 LED램프 조립구조
고효율광원, 저비용의 경제성을 갖춘 동시에
광도가 높고 균일한 빛을 제공하며
사각지대 없는 확산구조로 LED조명의 기대를 넘격히
충족시킨 광학설계 LED벽부등

Dimension

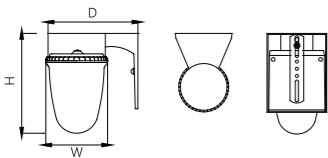
구분 Type	취부방식 Mounted Type	외측 사이즈 Size	타공 사이즈 Hole Size
	직부	Ø99(W)*169(H)*142(D)	-

Specification

구분 Type	모델명 Model name	물품식별번호 G2B	전력 Power consumptior	광효율 Luminous efficiency	연색성 CRI	색온도 Color temperature	취부방식 Mounted Type	인증 Certification	금액 Unit price
LED 벽부등	SKL-17GB-1050KS	23275614	10.5 W	90이상	80이상	5700K	직부	☞	60,000

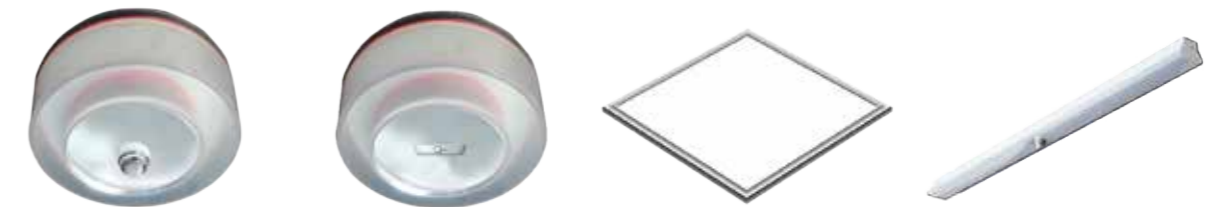

Dimension

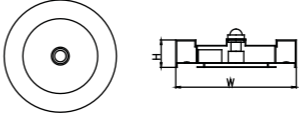
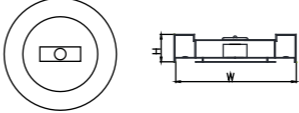
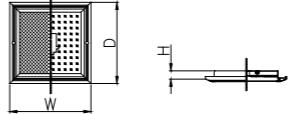
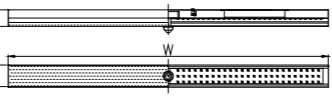
구분 Type	취부방식 Mounted Type	외측 사이즈 Size	타공 사이즈 Hole Size
	직부	Ø 200(W)*60(H)	-
	직부	Ø 200(W)*60(H)	-
	M-Bar	315(W)*315(D)*42(H)	300(W)*300(D)
	직부	1255(W)*87(D)*65(H)	-

Specification

구분 Type	모델명 Model name	물품식별번호 G2B	전력 Power consumptior	광효율 Luminous efficiency	연색성 CRI	색온도 Color temperature	취부방식 Mounted Type	인증 Certification	금액 Unit price
LED 센서등	SKL-14SS-0701WK		7W	75이상	80이상	5700K	직부	☞	
	SKL-18SS-0701WK		7W	75이상	80이상	5700K	직부	☞	
	SKLED-11MB-1101KG		11W	80이상	80이상	5700K	M-BAR	☞	
	SKLED-11RY-4001DG		25W	85이상	80이상	5700K	직부	☞	

 **서광조명**
www.intolux.co.kr

본사 및 공장

경기도 이천시 호법면 덕평로 243-20
TEL : 031) 637-5871~4, FAX : 031) 637-5876
E-mail : chomung@chol.com